



Dental Light

LUVIS | C500



* Be sure to read the manual before using this product.

1 03 Standards	2 04 Cautions and Warnings
3 08 Symbol	4 10 Introduction 4.1 Intended use 4.2 General description 4.3 Environmental requirement 4.4 Safety information 4.5 Warranty regulation 4.6 Electromagnetic compatibility
5 14 LIGHTHEAD specification 5.1 Technical specification (In accordance with EN/ISO 9680) 5.2 Electrical specification (In accordance with EN/ISO 60601-1) 5.3 Mechanical specification 5.4 Camera(optional) specification 5.5 Specification	6 15 Use 6.1 HEAD CONTROLLER 6.2 Remote controller(Optional) 6.3 HANDLE 6.4 SENSOR 6.5 Positioning
7 19 Performance characteristic 7.1 Adjusting the balancing of the ARM 7.2 Operating range of HEAD ARM 7.3 Operating range of MAIN ARM	8 25 Cleaning and Sterilization 8.1 Cleaning the equipment 8.2 MAIN HANDLE AUTOMATIC CLEANING 8.3 MAIN HANDLE MANUAL CLEANING 8.4 MAIN HANDLE Sterilization
9 27 Maintenance	11 31 Disposal
10 28 Troubleshooting 10.1 General troubleshooting 10.2 Mechanical troubleshooting	13 33 List of components
12 32 Model designation	15 35 Europe Representative

1. Standards

* Certification of DENTIS

- EN ISO 13485:2016
- Relevant EC Regulation: REGULATION (EU) 2017/745

* Applied Standards

- EN ISO 15223-1:2016, Medical devices – Symbols to be used with medical device labels, labelling and information to be supplied – Part 1: General requirements
- EN 1041:2008/A1:2013, Information supplied by the manufacturer with medical devices
- EN ISO 13485:2016, Medical devices – Quality management systems – Requirements for regulatory purpose
- EN ISO 14971:2019, Medical devices – Application of risk management to medical devices
- EN 60601-1:2006+A2:2021, Medical electrical equipment – Part 1: General requirements for basic safety and essential performance
- EN 60601-1-2:2015, Medical electrical equipment – Part 1-2: General requirements for basic safety and essential performance - Collateral standard: Electromagnetic disturbances – Requirements and tests
- EN 60601-1-6:2010, Medical electrical equipment-Part 1-6: General requirements for basic safety and essential performance – Collateral Standard: Usability
- EN ISO 7010:2019, Graphical symbols – Safety colors and safety signs-Registered safety signs
- EN 62471:2008, Photo biological safety of lamps and lamps systems
- EN 62366-1:2015, Medical devices – Application of usability engineering to medical devices
- EN ISO 9680:2021, Dentistry – Operating lights
- IEC 62304:2006/A1:2015, Medical device software, Software life-cycle processes
- EN IEC 80601-2-60:2020, Medical electrical equipment – Part 2-60: Particular requirements for the basic safety and essential performance of dental equipment

2. Cautions and Warnings

2. Cautions and Warnings

⚠ CAUTION(ATTENTION) This ME Equipment is intended only for use in the professional health-care facility environment, e.g. public and private hospitals, specialized medical offices, etc. This ME Equipment is intended for direct use on operation theatres and nearby HF surgical equipments, where the intensity of EM DISTURBANCES complies with the applicable standards. For further instructions please follow the chapter "Electromagnetic compatibility" of the User's Manual.

- Cet équipement ME est destiné uniquement à être utilisé dans l'environnement des établissements de santé professionnels, p. ex. hôpitaux publics et privés, cabinets médicaux spécialisés, etc. Cet équipement ME est destiné à être utilisé directement sur les salles d'opération et les équipements chirurgicaux HF situés à proximité, où l'intensité des perturbations électromagnétiques est conforme aux normes applicables. Pour de plus amples instructions, veuillez suivre le chapitre « Compatibilité électromagnétique » du Manuel de l'utilisateur.

⚠ CAUTION(ATTENTION) If this ME Equipment is lost or degraded the performance due to EM DISTURBANCES, result in improper operation and degradation of the performance.

- Si cet équipement est perdu ou dégradé en raison de perturbations électromagnétiques, il en résulte un mauvais fonctionnement et une dégradation de la performance.

⚠ CAUTION(ATTENTION) All cables and maximum lengths of coaxial cables that are replaceable by the DENTIS and that are likely to affect compliance of the this ME Equipment with the requirements of EMC(Electro-Magnetic compatibility). Do not modify this ME Equipment.

- Tous les câbles et longueurs maximales des câbles coaxiaux remplaçables par DENTIS et susceptibles d'affecter la conformité de cet ÉQUIPEMENT ME aux exigences de la CEM (Compatibilité Electro-Magnétique). Ne modifiez pas cet ÉQUIPEMENT ME.

⚠ CAUTION(ATTENTION) The EMISSIONS characteristics of this equipment make it suitable for use in industrial areas and hospitals (CISPR 11 Class A). If it is used in a residential environment (for which CISPR 11 Class B is normally required) this equipment might not offer adequate protection to radio-frequency communication services. The user might need to take mitigation measures, such as relocating or re-orienting the equipment.

- Les caractéristiques d'ÉMISSIONS de cet équipement le rendent adapté à une utilisation dans des zones industrielles et des hôpitaux (CISPR 11 classe A). S'il est utilisé dans un environnement résidentiel (où la classe B CISPR 11 est normalement requise), cet équipement pourrait ne pas offrir une protection adéquate aux services de communication radiofréquence. L'utilisateur pourrait devoir prendre des mesures d'atténuation, telles que déplacer ou réorienter l'équipement.

⚠ WARNING(AVERTISSEMENT) Use of this ME Equipment adjacent to or stacked with other equipment should be avoided because it could result in improper operation. If such use is necessary, this equipment and the other equipment should be observed to verify that they are operating normally.- L'utilisation de cet ÉQUIPEMENT ME à proximité ou empilé avec d'autres équipements doit être évitée car cela pourrait entraîner un fonctionnement incorrect. Si une telle utilisation est nécessaire, cet équipement et les autres équipements doivent être surveillés pour vérifier qu'ils fonctionnent normalement.

⚠ WARNING(AVERTISSEMENT) Use of accessories, transducers and cables other than those specified or provided by DENTIS of this ME Equipment could result in increased electromag-

netic emissions or decreased electromagnetic immunity of this equipment and result in improper operation.- L'utilisation de tous câbles et câbles coaxiaux autres que ceux spécifiés ou fournis par DENTIS pour cet équipement électromédical pourrait entraîner une augmentation des émissions électromagnétiques ou une diminution de l'immunité électromagnétique de cet équipement et provoquer un fonctionnement incorrect.

⚠ WARNING(AVERTISSEMENT) Portable RF communications equipment (including peripherals such as antenna cables and external antennas) should be used no closer than 30 cm(12 inches) to any part of the C500, including cables specified by DENTIS. Otherwise, degradation of the performance of this equipment could result.- Les équipements de communication RF portables (y compris les périphériques tels que les câbles d'antenne et les antennes externes) ne doivent pas être utilisés à moins de 30 cm (12 pouces) de toute partie du C500, y compris les câbles spécifiés par DENTIS. Sinon, une dégradation des performances de cet équipement pourrait en résulter.

⚠ WARNING(AVERTISSEMENT) The instructions given in this document must be followed when handling the product. Failure to do so may endanger the safety of the installers or users. As well as specific information on operating the entire product and conducting preventive maintenance, are provided in the USER'S MANUAL. For further information, please contact our sales network or our local network.- Les instructions données dans ce document doivent être suivies lors de la manipulation du produit. Ne pas le faire peut mettre en danger la sécurité des installateurs ou des utilisateurs. Des informations spécifiques sur le fonctionnement du produit dans son ensemble et sur l'exécution de la maintenance préventive sont fournies dans le MANUEL DE L'UTILISATEUR. Pour plus d'informations, veuillez contacter notre réseau de vente ou notre réseau local.

⚠ WARNING(AVERTISSEMENT) The electrical connections must be performed by a qualified technician only.

The electrical installation must be planned, performed and inspected by electrical engineers.
- Les connexions électriques doivent être effectuées uniquement par un technicien qualifié.
L'installation électrique doit être planifiée, réalisée et inspectée par des ingénieurs électriciens.

⚠ WARNING(AVERTISSEMENT) The LIGHTHEAD is designed to operate at AC 100-240V 50/60Hz(Adapter), AC 12-24V 50/60Hz(Non Adapter). Higher or lower voltages may affect the light intensity and operating life of the LEDs. Luvis(C500) is class I equipment for use with ADAPTER. In order to avoid the risk of an electric shock, the equipment must be connected to a mains supply with PE(protective earth).

- La TÊTE D'ÉCLAIRAGE est conçue pour fonctionner sur AC 100-240V 50/60Hz (AVEC ADAPTATEUR), AC 12-24V 50/60Hz (SANS ADAPTATEUR). Des tensions plus élevées ou plus basses peuvent affecter l'intensité lumineuse et la durée de vie des LED.

Le Luvis(C500) est un équipement de classe I à utiliser avec un ADAPTATEUR. Afin d'éviter tout risque de choc électrique, l'équipement doit être connecté à une alimentation secteur avec PE (terre de protection).

⚠ WARNING(AVERTISSEMENT) A main control switch must be installed for turning the system power-off.

Damaged wire insulation may result in the risk of electric shock.

- Un interrupteur principal doit être installé pour éteindre l'alimentation du système. Une isolation endommagée des fils peut entraîner un risque de choc électrique.

⚠ WARNING(AVERTISSEMENT) The power supplies may be installed and connected only by an electrician or a DENTIS authorized service agent.
- Les alimentations électriques ne peuvent être installées et connectées que par un électricien ou un agent de service autorisé par DENTIS.

⚠ WARNING(AVERTISSEMENT) This product may only be repaired and special assembly work may only be carried out by DENTIS or a company that has been authorized by DENTIS.
- Ce produit ne peut être réparé et des travaux d'assemblage spéciaux ne peuvent être effectués que par DENTIS ou une entreprise autorisée par DENTIS.

⚠ WARNING(AVERTISSEMENT) Check the polarity of all electrical connections before turning on the power.
- Vérifiez la polarité de toutes les connexions électriques avant d'allumer l'alimentation.

⚠ WARNING(AVERTISSEMENT) The LIGHTHEAD brakes are adjusted during installation. Like all mechanical parts, the brakes are subject to wear. Check the condition of the mounting surface.
- Les freins de la TÊTE LUMINEUSE sont réglés lors de l'installation. Comme toutes les pièces mécaniques, les freins sont sujets à l'usure. Vérifiez l'état de la surface de montage.

⚠ WARNING(AVERTISSEMENT) Do not look directly into light source(LED).
- Ne regardez pas directement la source lumineuse (LED).

⚠ WARNING(AVERTISSEMENT) The operation and safety of the device may be affected by the removal of certain components during servicing operations.
- Le fonctionnement et la sécurité de l'appareil peuvent être affectés par le retrait de certains composants lors des opérations d'entretien.

⚠ WARNING(AVERTISSEMENT) All the information in this manual has been checked out carefully and discerned as accurate one at the time of publication. However, DENTIS takes no responsibilities of the results caused by default, omission, or misuse of it.
- Toutes les informations contenues dans ce manuel ont été soigneusement vérifiées et jugées exactes au moment de la publication. Cependant, DENTIS décline toute responsabilité pour les résultats causés par des défauts, des omissions ou une mauvaise utilisation de celles-ci.

















⚠ WARNING(AVERTISSEMENT) DENTIS has rights to modify the product itself or specifications of the product without any prior notice, as well as rights not to renew that modification on this manual.
- DENTIS se réserve le droit de modifier le produit lui-même ou les spécifications du produit sans préavis, ainsi que le droit de ne pas renouveler cette modification dans ce manuel.









⚠ WARNING(AVERTISSEMENT) Do not press more than two buttons simultaneously.
In case of abnormal operation (overpower) of this product, stop the medical treatment and contact the place of purchase.
- Ne pas appuyer sur plus de deux boutons simultanément. En cas de fonctionnement anormal (surcharge) de ce produit, arrêtez le traitement médical et contactez le lieu d'achat.

⚠ WARNING(AVERTISSEMENT) The circuit of medical device must be installed in the state with the means to electrically separate with in all poles from the POWER SUPPLY.
- Le circuit du dispositif médical doit être installé dans un état permettant une séparation électrique de tous les pôles de l'ALIMENTATION.

⚠ WARNING(AVERTISSEMENT) When using the Adapter type, be sure to make easy connect and disconnect the power cord.
- Lorsque vous utilisez le type Adaptateur, assurez-vous de faciliter la connexion et la déconnexion du cordon d'alimentation.

3. Symbol

Symbol (Symbole)	Meaning (Signification)	Remark (Remarque)
	CE Mark The device bears the CE mark and complies with the requirements of Regulation (EU) MDR 2017/745 for medical device. - L'appareil porte le marquage CE et est conforme aux exigences du Règlement (UE) MDR 2017/745 relatif aux dispositifs médicaux.	④, ⑤, ⑥
	MEDICAL – GENERAL MEDICAL EQUIPMENT AS TO ELECTRICAL SHOCK, FIRE AND MECHANICAL HAZARDS ONLY IN ACCORDANCE WITH [ANSI/AAMI ES60601-1:2005/(R)2012 and A1:2012, C1:2009/(R)2012 and A2:2010/(R)2012, CAN/CSA C22.2 No. 60601-1:14] - MATÉRIEL MÉDICAL – GÉNÉRALITÉS CONCERNANT LES CHOCS ÉLECTRIQUES, LES INCENDIES ET LES DANGERS MÉCANIQUES SEULEMENT CONFORMÉMENT AUX [ANSI/AAMIES 60601-1:2005/(R)2012 et A1:2009/(R)2012/(R)2012, CAN/CSA C222 No. 60-114]	④, ⑤, ⑥
	Recommendation - Recommandation	⑤
	Protective earth (ground) - Terre de protection	②
	Alternating current - Courant alternative	②
	Stand-by - Mode veille	③
	Do not throw away with general household waste - Ne pas jeter avec les déchets ménagers ordinaires	④, ⑤, ⑥
	Caution - ATTENTION	⑤
	Warning - AVERTISSEMENT	⑤
	Operating instructions - Suivre les instructions d'utilisation	⑤
	Follow instructions for use - Action obligatoire générale	⑥
	General mandatory action - Pousser interdit	①
	Pushing prohibited - GARDER À L'ÉCART DE LA PLUIE	①
	KEEP AWAY FROM RAIN - NE PAS UTILISER DE CROCHETS À MAIN	④
	USE NO HAND HOOKS - FRAGILE, MANIPULER AVEC PRÉCAUTION	④
	FRAGILE, HANDLE WITH CARE - TOUJOURS GARDER DANS CE SENS	④
	THIS WAY UP	④

Symbol (Symbole)	Meaning (Signification)	Remark (Remarque)
	Do not build up more than 5 boxes - Ne pas empiler plus de 5 boîtes	④
	Manufacturer - Fabricant	④, ⑤, ⑥
	Europe Representative - Représentant en Europe	⑤, ⑥
	Date of manufacture - Date de fabrication	⑤, ⑥
	Temperature between 0 - 40°C - Température entre 0 - 40°C	④
	Humidity between 0 - 80%RH - Humidité entre 0 - 80 %HR	④
	Atmospheric pressure between 80Kpa – 106Kpa - Pression atmosphérique entre 80 kPa – 106 kPa	④
	Recycling - Recyclage	④, ⑤

No.	Location (Emplacement)
①	Marking on the outside of ME EQUIPMENT - Marquage à l'extérieur de l'ÉQUIPEMENT ME
②	Marking on the inside of ME EQUIPMENT - Marquage à l'intérieur de l'ÉQUIPEMENT ME
③	Marking on the controls of ME EQUIPMENT - Marquage sur les commandes de l'ÉQUIPEMENT ME
④	Marking on the packing label of ME EQUIPMENT - Marquage sur l'étiquette d'emballage de l'ÉQUIPEMENT ME
⑤	Marking on the manual of ME EQUIPMENT - Marquage sur le manuel de l'ÉQUIPEMENT ME
⑥	Marking on the label of ME EQUIPMENT - Marquage sur l'étiquette de l'ÉQUIPEMENT ME

4. Introduction

4.1 Intended use

- Dental Light (C500) is intended to be used to provide visible illumination of the Dental Light (C500) area or the patient during dental surgery, diagnosis and treatment.
- Classification under the provision of 93/42/EEC(MDR) : Class I
 - Dental Light (C500) is classified as a Class I device.
- Classification under the provision of FDA (U.S. Food and Drug Administration) : Class I
 - Dental Light (C500) is classified as a Class I device.
- Form of protection against electric shock : Class I
 - Dental Light (C500) is classified as Class I
- Degree of protection against flammability
 - Dental Light (C500) is classified as a device not suitable to be used in a potentially flammable environment.
 - Do not use near flammable materials.
- Method(s) of sterilization or disinfection recommended by the manufacturer.
 - The HANDLE should be cleaned with cloths
 - The HANDLE should be sterilized with sterilizer regularly to prevent infection.
- Mode of operation
 - Classification of Dental Light (C500) : continuous operation.

4.2 General description

- The user must ensure that the device works properly and is in a satisfactory condition before each use.
- This DENTIS device is intended only for use in the field of medical. It is impermissible to use the device for a purpose for which it was not intended.
- "Proper Use" includes following all the instructions for use and ensuring that all inspections and service tasks are performed.
- Apply and meet the overarching guidelines and/or national laws, national regulations and the rules of technology for medical devices applicable for startup and use of the device for the intended purpose.
- The user must observe the following :
 - Only use properly operating equipment.
 - Protect himself or herself and third parties from danger.
 - Avoid contamination from the device.
- During use, the following national regulations must be observed:
 - The applicable health and safety regulations.
 - The applicable accident prevention regulations.
- To ensure that device maintains their value and are always ready for use, they must be serviced once a year as recommended.
- Before using the products, You must receive training by authorized person of the DENTIS.
- The safety checks must be performed every year.

- Repair and service of the device is authorized only to those who meet the requirements below:
 - Technicians of authorized dealers specially trained by DENTIS.
 - The trained technicians of DENTIS branches.

4.3 Environmental requirement

- | | |
|--|--|
| · Conditions of the usage environment | · Conditions of storage and transportation environment |
| - Temperature : 0 - 40°C | - Temperature : 0 - 40 °C |
| - Relative Humidity : 30 - 90 %RH | - Relative Humidity : 0 - 80 % |
| - Atmospheric pressure: 0 - 2,000 m (106-80 Kpa) | - Atmospheric pressure: 0 - 2,000 m (106 - 80 Kpa) |

4.4 Safety information

- Dental Light (C500) as a medical device complies with the safety regulation EN/IEC 60601-1.
- Accessory equipment connected to the analog and digital interfaces must be certified according to the respective EN/IEC standards (e.g. EN/ISO 9680 for Dentistry-Operating lights, EN/IEC 60601-1 for General Medical equipment).
- Furthermore all configurations shall comply with the ME Equipment of Collateral Standard EN/IEC 60601-1-2. Everybody who connects additional equipment to the signal input part or signal output part configures a ME Equipment, and is therefore responsible that the ME Equipment complies with the requirements of standard EN/IEC 60601-1.
- If in doubt, consult the technical service department or your local representative.
- For EU Countries
 - Europe Representative
KTR Europe GmbH
Mergenthalerallee 77, 65760 Eschborn, Germany
- Safety is everyone's obligation and responsibility.
- The safe use of this product is related to everyone such as installer, user, operator and equipment's manager.
- It must read and learn this user's manual is compulsory before installation, using, cleaning, fixing or operation of this product or its accessories. Pay particular attention and be familiar with warning symbols about safety.
- If do not follow safety direction of this manual, you can get injured or accident when you operate this product. After read carefully and understand this manual, use this product.
- This manual is in keep a place where you can find easily.



4.5 Warranty regulation

- DENTIS warrants all products against defects in materials or workmanship for two year from time of delivery.
- DENTIS's sole obligation under the warranty is to provide parts for the repair, or at its option, to provide the replacement product (excluding labor).
- The buyer shall have no other remedy. All special, incidental, and coincidental damages are excluded.
- Written notice of breach must be given to DENTIS within the warranty period.
- The warranty does not cover damage resulting from improper installation or maintenance, accident or misuse.
- The warranty does not cover damage resulting from the use of cleaning, disinfecting or sterilization chemicals and processes.
- The Failure to follow instructions provided in the DENTIS Instructions for Use (operation and maintenance instructions) may void the warranty.
- LED PCB Ass'y is covered under 60,000 hrs warranty.

4.6 Electromagnetic Compatibility

4.6.1 Emission

This ME equipment is intended for use in Professional healthcare facility environment.		
Emission test	Compliance	Guidance
Conducted Disturbance CISPR 11(EN 55011)	Complies (Group 1, Class A)	This ME equipment uses RF energy only for its internal function. Therefore, its RF emissions are very low and are not likely to cause any interference in nearby electronic equipment.
Radiated Disturbance CISPR 11(EN 55011)		
Harmonic current IEC 61000-3-2	Complies	This ME equipment is suitable for use in all establishments other than domestic premises and those directly connected to the public low-voltage power supply network that supplies buildings used for domestic purposes.
Voltage fluctuations and flicker IEC 61000-3-3	Complies	

4.6.2 Immunity

This ME equipment is intended for use in Professional healthcare facility environment.			
Immunity test	EN 60601-1-2:2015		Compliance
Electrostatic Discharge(ESD) IEC 61000-4-2	Direct: ± 8 kV Contact ± 2 kV, ± 4 kV, ± 8 kV, ± 15 kV Air Indirect: ± 8 kV HCP/VCP		Complies
Radio Frequency Electromagnetic Fields IEC 61000-4-3	3 V/m @ 80 MHz ~ 2.7 GHz 80 % AM at 1 kHz		Complies
Proximity fields from RF wireless communications equipment IEC 61000-4-3	Frequency (MHz)	Modulation	Immunity Level (V/m)
	385	**Pulse Modulation: 18 Hz	27
	450	*FM ± 5Hz deviation: 1 kHz sine	28
	710 745 780	**Pulse Modulation: 217 Hz	9
	810 870 930	**Pulse Modulation: 18 Hz	28
	1 720 1 845 1 970	**Pulse Modulation: 217 Hz	28
	2 450	**Pulse Modulation: 217 Hz	28
	5 240 5 500 5 785	**Pulse Modulation: 217 Hz	9
** The carrier shall be modulated using a 50 % duty cycle square wave signal. * As an alternative to FM modulation, 50 % pulse modulation at 18 Hz may be used because while it does not represent actual modulation, it would be worst case.			
Fast Transients IEC 61000-4-4	Voltage	AC/DC power ports	Signal ports
	Test voltage	± 2 kV	± 1 kV
- 100 kHz repetition frequency			
Surges IEC 61000-4-5	Voltage	Power lines	
	Test voltage	Line to Line : ± 0.5 kV, ± 1 kV Line to ground: ± 0.5 kV, ± 1 kV, ± 2 kV	
RF Continuous Conducted IEC 61000-4-6	3 V @ 0.15 MHz ~ 80 MHz 6 V @ in ISM bands between 0.15 MHz and 80 MHz 80 % AM at 1 kHz		Complies
Power Frequency Magnetic Fields IEC 61000-4-8	30 A/m @ 50 Hz or 60 Hz		Complies
Voltage Dips, Interruptions, and Variations IEC 61000-4-11	<ul style="list-style-type: none"> • Voltage Dips 0 % UT; 0,5 cycle At 0°, 45°, 90°, 135°, 180°, 225°, 270° and 315° 0 % UT; 1 cycle and 70 % UT; 25/30 cycles Single phase: at 0° • Voltage Interruptions 0 % UT; 250/300 cycle • Voltage Variations 		
	Frequency (Hz)	Ranges	
	50	49, 50, 51	
60	59, 60, 61		
Complies			

5. LIGHTHEAD specification

5.1 Technical specification (In accordance with EN/ISO 9680)

· STANDARD SPECIFICATION

Specifications		Unit	Luvis C500		Remark
			DENTAL	RESIN	
Central illuminance Ec (@700mm)	Max.	lx	50,000	10,000	
	Irradiance (Ee)	W/m ²	< 200	< 50	
Illuminance in patient's eyes		lx	≤ 1,000		
Hard shadow		mm	7 X 3		
Focal Distance		mm	700		
Size of area(inside pattern A)		mm	70 × 35		Oval shape
Size of area(outside pattern B)		mm	95 × 50		Oval shape
Pattern Size		mm	160 × 90		Horizontal Axis
Color temperature (3steps)		K	4,000/4,500/5,000	-	Selectable
Color fidelity index (Ra, Rf)		N/A	95	-	@ 4,000K

* Optical values are measured with a tolerance of ±10%

5.2 Electrical specification (In accordance with EN/IEC 60601-1)

· TECHNICAL DATA

Content	Specification	Remark
C500	AC 12-24V, 50/60Hz, 21VA	Without Adapter
	Head : DC 15V, 1.5A AC/DC Adapter - Input : 100-240V, 50/60Hz, 1.6-0.7A - Output : DC 15V, 4.34A	Adapter type

⚠ WARNING: Please use be connected to a chair unit that can limit the power supply.
If the power supply is not a dental chair unit, use the special ADAPTER, which Must provided by the DENTIS.

5.3 Mechanical specification

Specifications	Length(mm)	Weight(kg)	Remark
LIGHTHEAD	284 × 165 x 118	1.6	Head
		1.95	With INTERNAL CAMERA
MAIN ARM	-	4.4	FIRST MAIN ARM + SECOND MAIN ARM
WALL BRACKET	-	2.3	
CEILING VERTICAL ARM	Φ42.7×733	5	
CEILING COVER & BRACKET	Φ500×50	1.15	
CEILING MOUNTING SET	-	13.36	GUIDE BRACKET + FIX BRACKET + STUD BOLT
MOBILE VERTICAL ARM	-	6.5	
MOBILE BASE	-	19.38	CASTER 4EA

5.4 CAMERA(optional) specification

Content	Specifications		Remark
Type	FULL HD (KTNC)	4K (SONY)	
Zoom Ratio	30X Optical Zoom	20X Optical Zoom	
Min. Object Distance	600mm to 800mm	600mm to 800mm	
Image Point	Approx. 2.13 Megapixels	Approx. 8.51 Megapixels	
Image Sensor	1/2.8" SONY STARVIS COMS	1/2.5 – Type Exmor R	
Video System	Full HD 1080p	4K : 2160	
Video Output Signal	HD-SDI	6G-SDI	75Ω BNC

5.5 Specification

Specifications	Luvis C500	Remark
Protection against electric shock	Class I Protection	Adapter
Protection against electric shock	Non-Class	Chair unit
Protection against harmful ingress of water or particulate matter	Ordinary	Head part: IPx0

6. Use





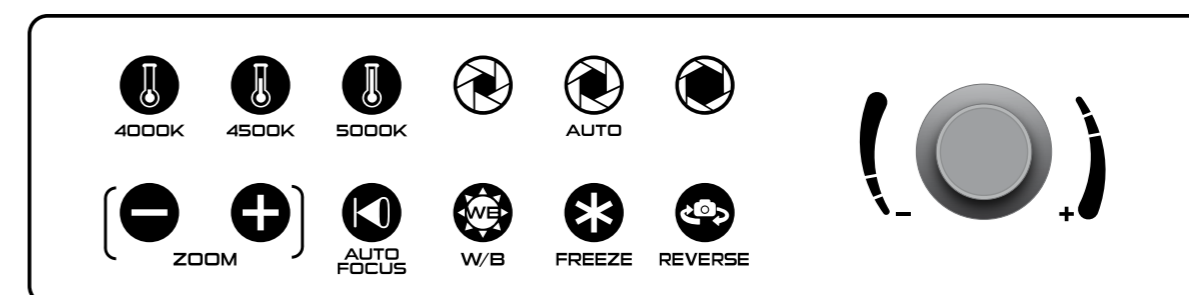

6.1 HEAD CONTROLLER

· The LED DENTAL LIGHT can be controlled using the HEAD CONTROLLER

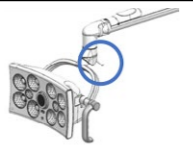
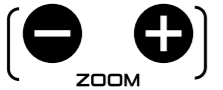

Illumination Function		
	MAIN POWER SWITCH	· LIGHTHEAD power on/off
	Brightness Control	· Dial type (option, remote controllable) · Clockwise rotation → Brightness up. · Counter clockwise rotation → brightness down · 6 ~ 100% of control range.
	Color temperature	· 4,000K / 4,500K / 5,000K

6.1 HEAD CONTROLLER

CAMERA (Option)		
	MAIN POWER SWITCH	· CAMERA power on/off · The LIGHTHEAD and CAMERA turn on and off simultaneously with the main power switch
	Zoom IN/OUT	· Camera ZOOM IN (+), ZOOM OUT(-)
	Adjustment of Brightness	· Control the Brightness of camera
	Auto Focus	· Control the focus of camera automatically.
	White Balance	· Control the White Balance of camera
	Freeze	· Temporarily Freeze the screen
	Reverse	· Left & Right Reverse

6.2 Remote controller (Optional)

· The LED DENTAL LIGHT can be controlled using the Remote Control

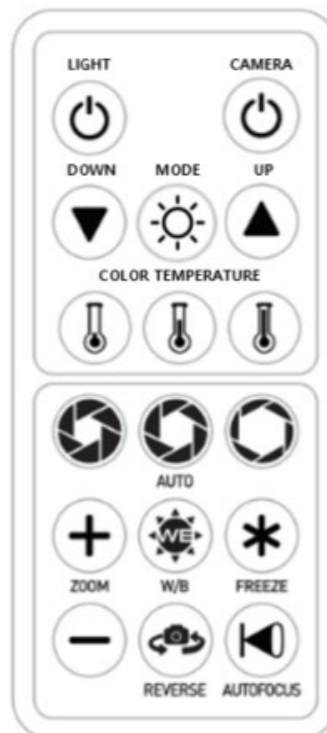

< Brightness control in 6 levels >

· Other Functions will work same as control panel

⚠ Operation of remote controller is prohibited by unauthorized personnels. Use a correct coin battery rated as DC 3V, CR2025.

<The control panel of the Remote Control >

6.3 HANDLE

⚠ Check the attachment and detachment before using the product.
Check that the product is cracked and attached properly

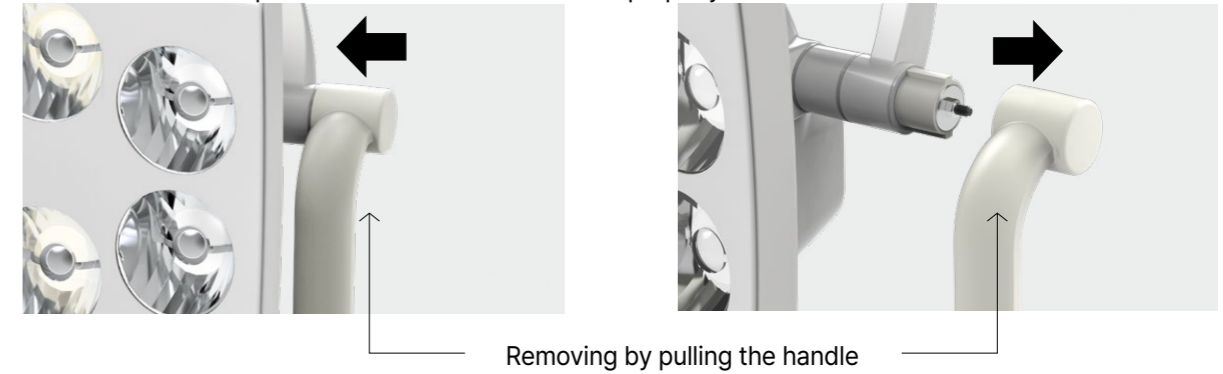

Removing by pulling the handle

* Mounting HANDLE

- Insert the HANDLE to fixed the mount
- Check Rotate to the left or right

* Remove the HANDLE

- Pull the HANDLE to remove

6.4 SENSOR



Motion Sensor
Mode(Dental, Resin, On/Off) Rotate
sensing distance 2cm

7. Performance characteristic

7.1 Adjusting the balancing of the ARM

6.5 Positioning

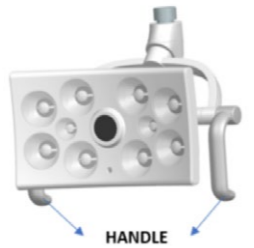
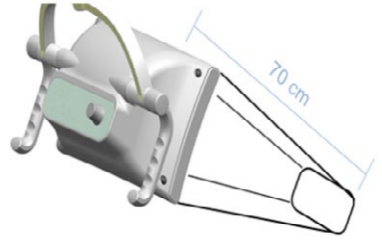
Positioning the C500 LIGHTHEAD	
	
<ul style="list-style-type: none"> · Use the HANDLE to position the C500 LIGHTHEAD before the operation. · This HANDLE can be detached for sterilization. 	<ul style="list-style-type: none"> · Recommended distance : 700mm
<p style="text-align: center;">Pattern Size (unit : mm)</p>	

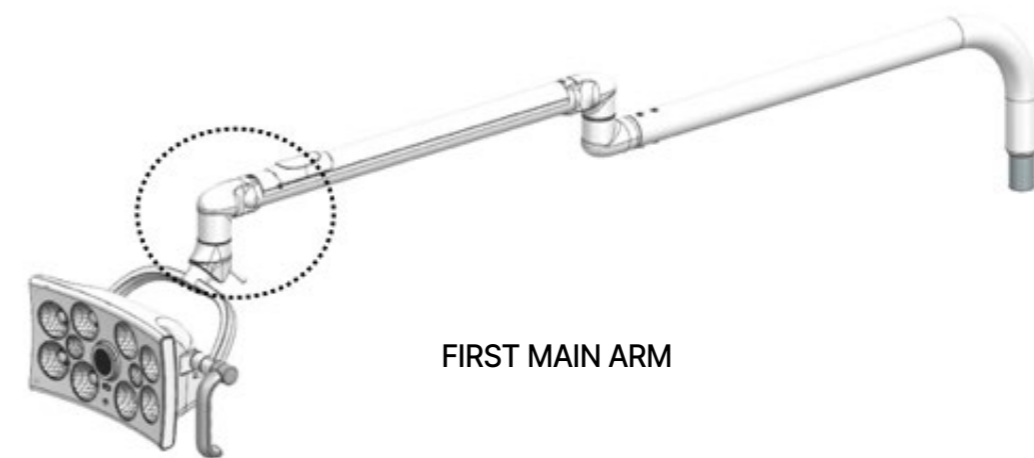
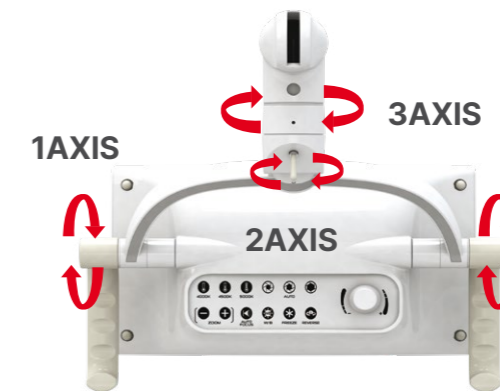
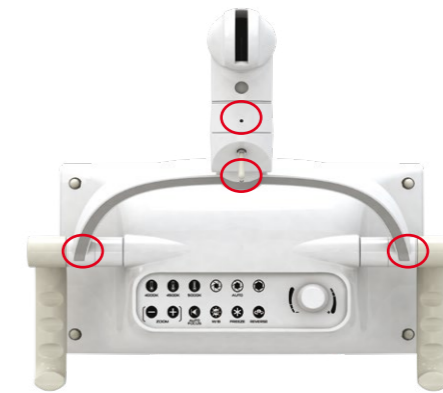

⚠ FIRST MAIN ARM contains a powerful spring. When the LIGHTHEAD is dismantled, the SPRING ARM can suddenly jump up and may cause serious injury. Make sure the apparent weight of the LIGHTHEAD is the same when raised and lowered and that it is stable in any position.

7.2 Operating range of HEAD ARM

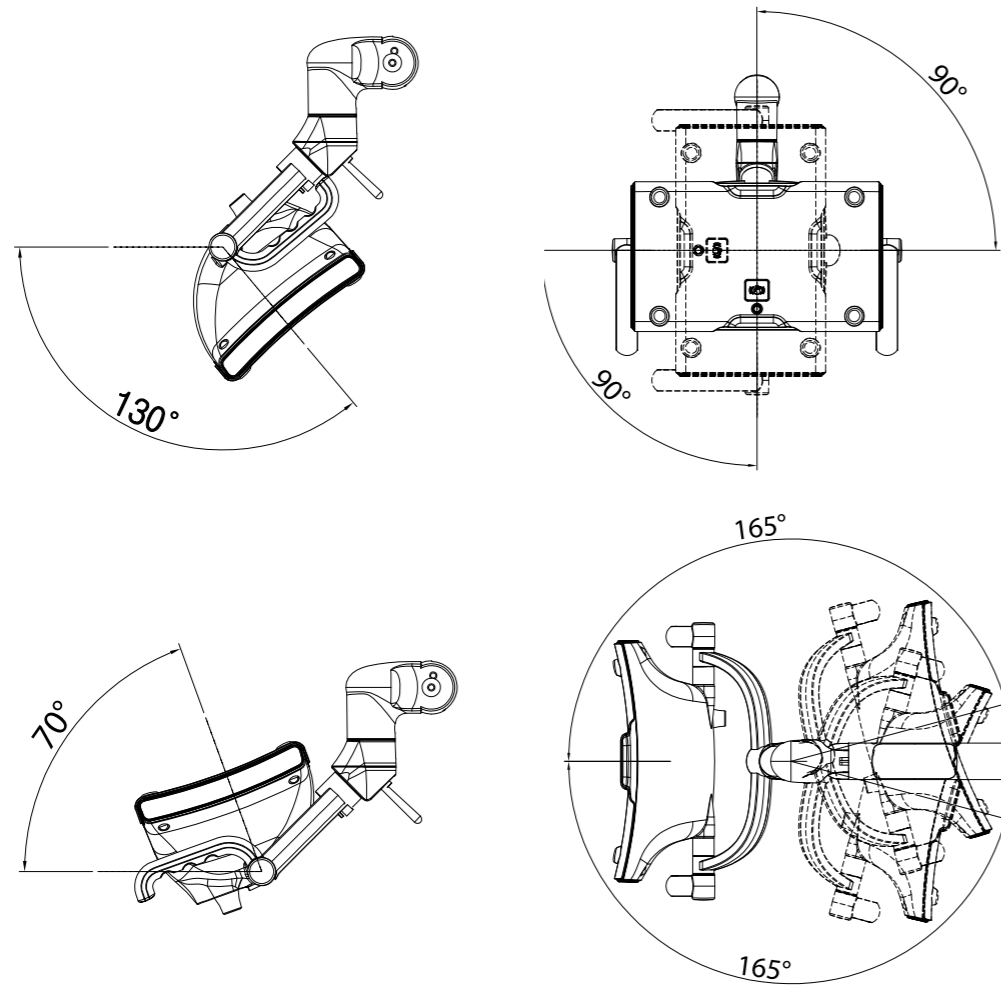

7.3 Operating range of MAIN ARM

· CHAIR TYPE

(Unit : mm)

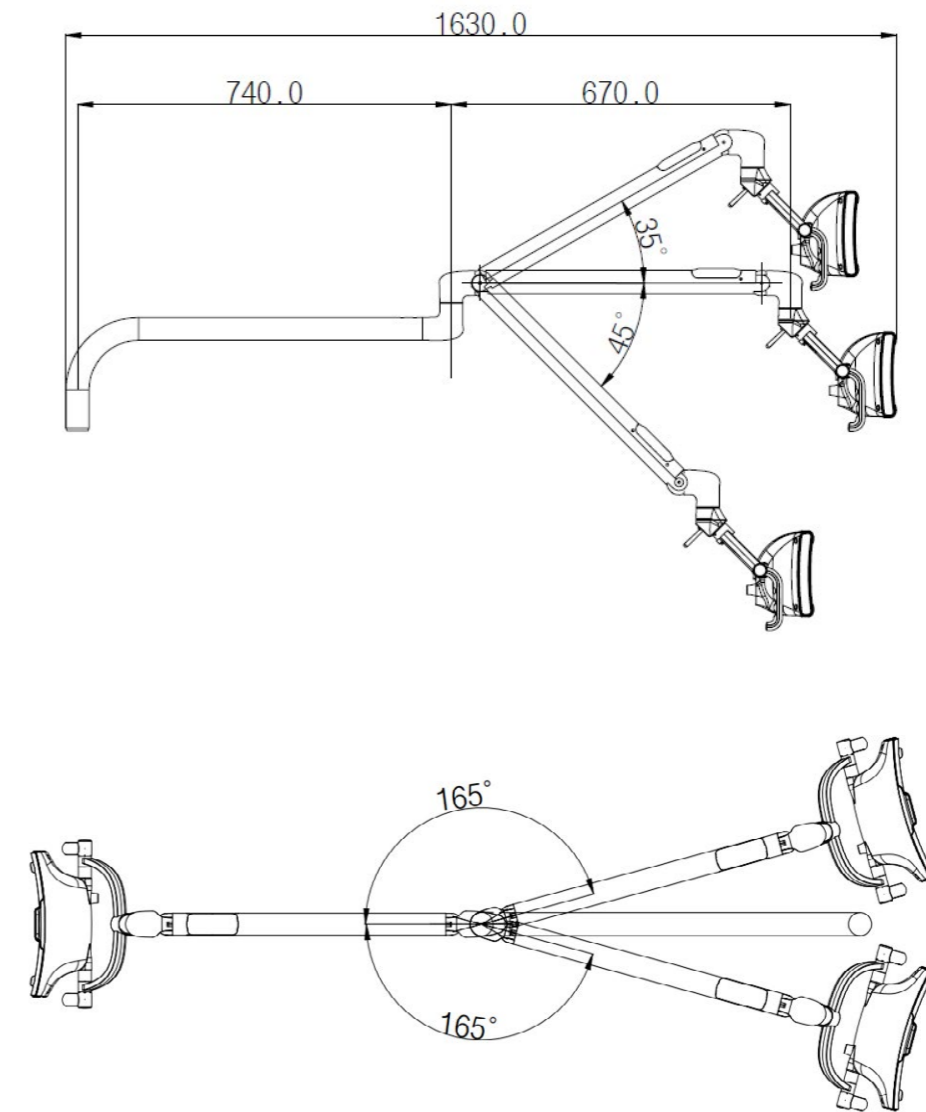

⚠ If this device is operated beyond the indicated angles, it can be damaged. During positioning, eventual collisions between the LIGHTHEAD, SPRING ARMS and other devices must be avoided.

⚠ This image was constructed to demonstrate the product's operating range. The image may differ from the actual product.

⚠ Do not place things on or hang on MAIN ARM.

⚠ If this device is operated beyond the indicated angles, it can be damaged.

· MOBILE TYPE

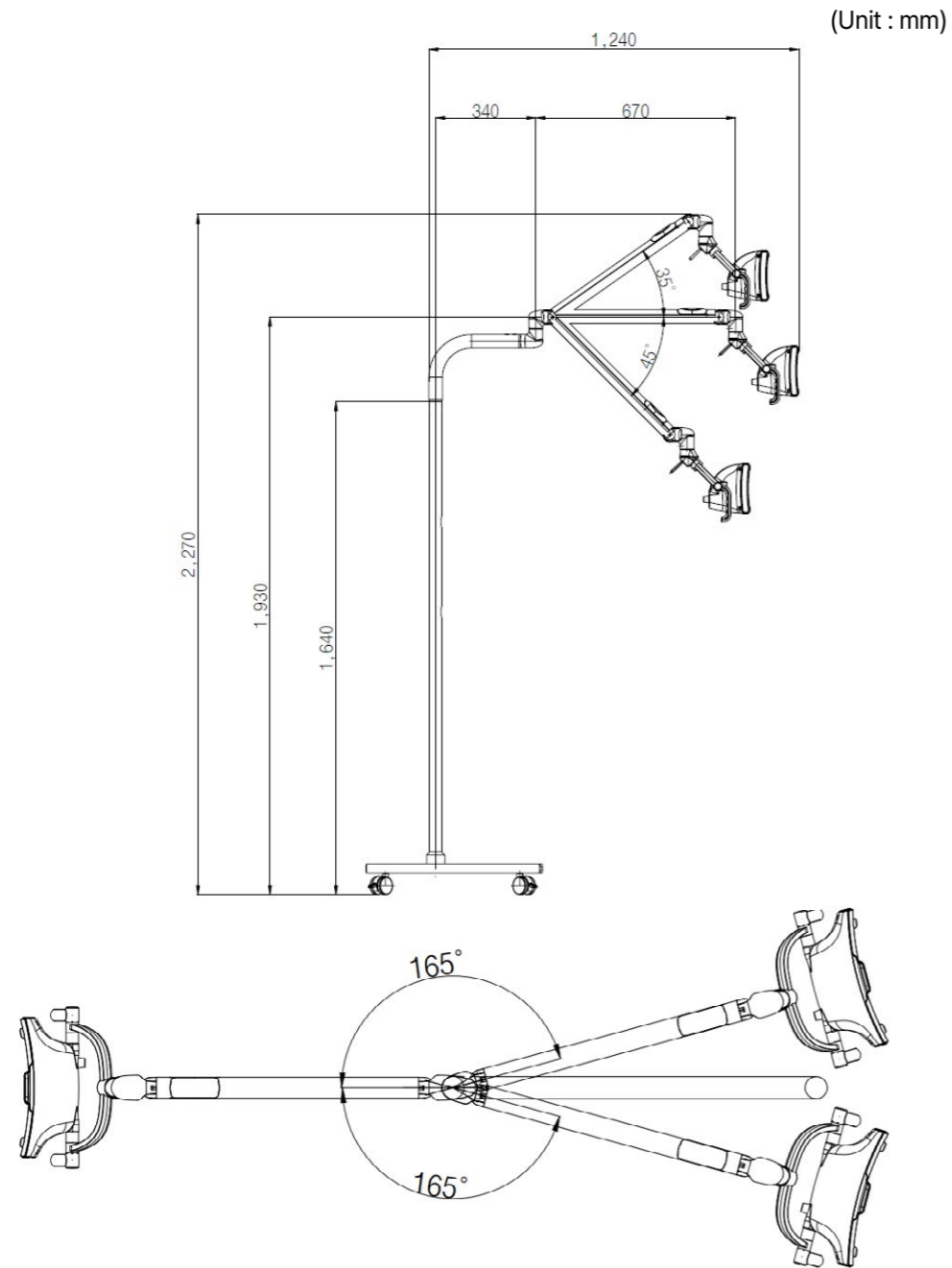

· WALL TYPE

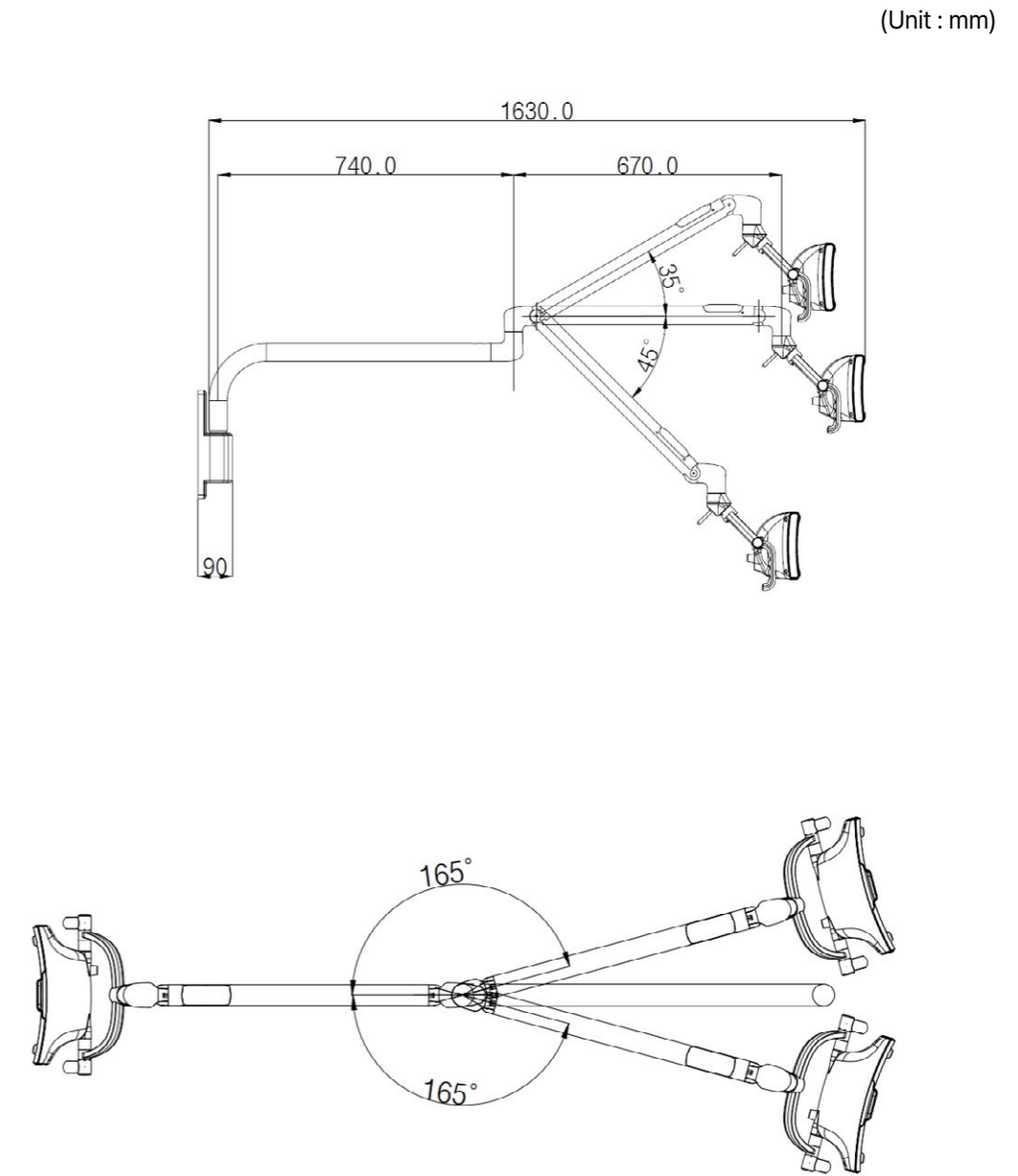

- ⚠ Do not place things on or hang on MAIN ARM.
- ⚠ If this device is operated beyond the indicated angles, it can be damaged.

- ⚠ Do not place things on or hang on MAIN ARM.
- ⚠ If this device is operated beyond the indicated angles, it can be damaged.

· CEILING TYPE

(Unit : mm)

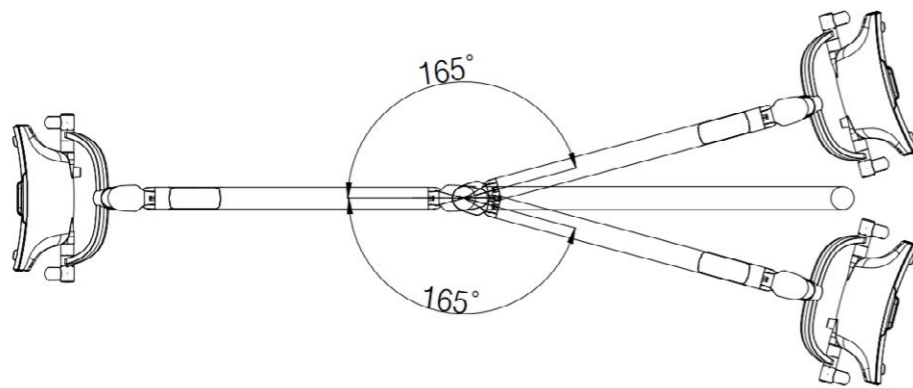
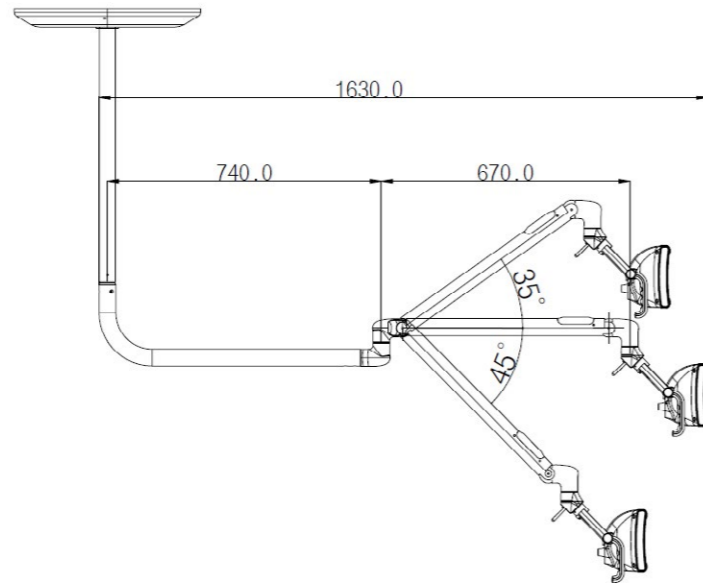

- ⚠ Do not place things on or hang on MAIN ARM.
- ⚠ If this device is operated beyond the indicated angles, it can be damaged.

8. Cleaning and Sterilization

⚠ Cleaning and sterilization procedures vary from facility to facility and therefore it is not possible to specify a single procedure. The user should contact a specialist in the hospital and apply the recommended procedures according to the product. If you have any questions about the compatibility of your medication, please contact the DENTIS Customer Center.

The treatment level required for cleaning and disinfection of the MAIN HANDLE is a low level of disinfection. It is classified as non-critical devices with a low risk of infection, except for the use of sterilizable handles.

Contact your place of purchase in case of failure or damage.

- ⚠ The use of cleaning agents containing the following substances is not permitted.
 - High concentrations of organic and inorganic acids and chlorinated hydrocarbons

8.1 Cleaning the equipment

- ⚠ Before cleaning turn off the power and wait until LIGHTHEAD is sufficiently cooled.
 - Wear gloves when cleaning and disinfecting.
 - Do not spray cleaning and disinfectant directly into the LIGHTHEAD.

- Make sure that the system is powered off and the LIGHTHEAD is sufficiently cooled.
- Prepare cleaning agents and disinfectants. For cleaning agents, follow the manufacturer's instructions for use.
- Moisten a clean, lint-free, soft cloth with cleaning solution and remove excess moisture.
- Clean the area using a cloth soaked with cleaning agent.
- Clean the device using a cloth soaked with clean water.
- Wipe all surfaces with a clean, dry cloth to remove any residue.
- Make sure all cleaning and disinfectant residues have been removed before using the light.

8.2 MAIN HANDLE AUTOMATIC CLEANING

- After the treatment, remove the MAIN HANDLE from the dental lamp.
- Remove visible foreign substances using a soft brush and cloth in warm water flowing through the MAIN HANDLE for at least 1 minute.
- Place the MAIN HANDLE in the cleaning equipment and carry out the cleaning using an enzyme detergent according to the following cleaning conditions.

No.	Condition	Temperature(°C)	Minimum time(Min)
1	Pre-cleaning	20-40	1
2	Cleaning	20-40	5
3	Cleaning	20-40	2
4	Rinsing	20-40	10
5	Rinsing	20-40	10
6	Dry	50-70	90

- Remove the MAIN HANDLE from the cleaning equipment and ensure that the cleaning is complete.
- Check for foreign substances left inside and outside the MAIN HANDLE, if it is necessary, repeat the cleaning process
- Protect the cleaned and dried MAIN HANDLE from re-contamination.

8.3 MAIN HANDLE MANUAL CLEANING

- After the treatment, remove the MAIN HANDLE from the dental lamp.
- Immerse the MAIN HANDLE in the washing tank for at least 5 minutes in the diluted enzyme detergent. (Follow the manufacturer's instructions for use of the cleaner.)
- To prevent blood or foreign substances from drying out, soak the separated MAIN HANDLE in distilled water or tap water for 15 minutes to remove any foreign substances, then clean it with a soft brush and a lint-free cloth.
- Check inside and outside of the MAIN HANDLE for debris, and repeat cleaning if any debris remains.
- Rinse thoroughly with clean water and wipe clean with a lint-free cloth to dry.
- Protect the cleaned and dried main handle from re-contamination

8.4 MAIN HANDLE Sterilization

- ⚠** Do not allow foreign substances to enter the MAIN HANDLE during sterilization. MAIN HANDLE is guaranteed for up to 100 sterilization cycles when the same sterilization conditions are applied.
- In the case of MAIN HANDLE, sterilization may cause wear, cracks, and discoloration. If these signs are detected, stop using the handle and replace it.
- The MAIN HANDLE being stored must be kept clean and sterile before use.
- If you are not wearing a sterile suit, be careful and do not touch the sterilized MAIN HANDLE.

- Sterilize the cleaned MAIN HANDLE according to the process below.
- Make sure the MAIN HANDLE is clean, wrap the HANDLE in sterile packaging (double packaging or equivalent) and seal it.
- When putting the MAIN HANDLE into the sterilizer, make sure that the hole is facing down to allow water to flow down.
- Place the MAIN HANDLE in the Pressurized Steam Sterilizer (AUTO CLAVE) and proceed with the sterilization cycle according to the sterilization conditions. Using chemical sterilization is prohibited
- Follow the sterilizer manufacturer's instructions and sterilization conditions of your country.
- When storing after sterilization, store in a tray in a sterile packaging material.(room temperature storage)

Sterilization Condition	
<ul style="list-style-type: none"> · Operating Condition <ul style="list-style-type: none"> - Temperature : 132 °C - Pressure : 160 ± 50kPa (1.6 ±0.5 kgf/cm²) - Time : 10 min - Dry : 16 min 	 <p>Autoclave</p>
Sterile Packaging	
<ul style="list-style-type: none"> · Sterile Clothing <ul style="list-style-type: none"> - KIMGUARD sterile clothing - Model : KC500 	

9. Maintenance



- ⚠** A electrical and mechanical check-up should be done every year.
- Disconnect the pendant system from the mains before any maintenance work to prevent electric shock.
- ⚠** Check points on maintenance work
- Defects of paint
 - Plastic fissures
 - Loosened parts.
 - Free rotatability / limit stops and deformation of the suspension.
 - The connection between LIGHTHEAD and pendant system.
 - The faultless function of the LIGHTHEAD.
- ⚠** In case of failure or damage, please contact your supplier.

10. Troubleshooting



10.1 General Troubleshooting

No	Problem	Cause	Corrective action
1	If the LED light on the LIGHTHEAD does not turn on.	Power cut	Check if supply mains are operating.
		Others	Press the stand-by button of the control panel and check that the LED turns on. (If green light does not light on, do not attempt to repair it yourself, please contact your supplier)
2	If there is an error in the light pattern formation.	Inappropriate distance	Check if recommended distance(70cm) between the LIGHTHEAD to the chair unit. If the condition does not improve, do not attempt to repair. Please contact your supplier.
3	If the SAFETY COVER of the LIGHTHEAD is polluted.	Pollution	Cleanse it with designated chemicals (Alcohol, Ethanol). If the essential performances of the device (Intensity of Illumination, Color Temperature) are seriously impaired, please contact your supplier.

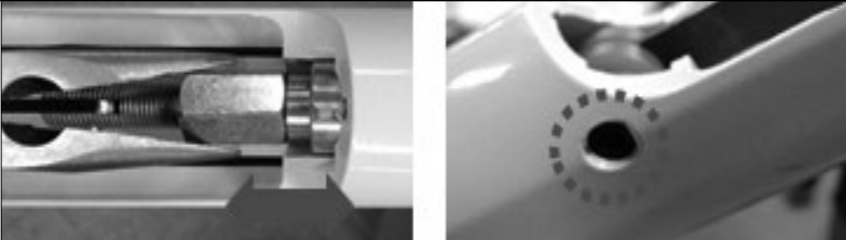
10.2 Mechanical troubleshooting

No.	Problem	Corrective action
1	Removal Arm Cover (common application)	 <ul style="list-style-type: none"> Remove the cover using '-driver (3mm below) <p>⚠ Avoid peeling of the paint on the arm Avoid Arm cover hook broken</p>
	Tension control method	 <ul style="list-style-type: none"> Lower FIRST MAIN ARM as much as possible Fixing bolt with the same number of rotations (Use 3mm allen wrench) <p>⚠ In case up & down move is not natural, release damper bolt a little bit. The damper bolt must be secured so that the damper is always centered. Avoid Hexagon nut broken</p>
	In case of less tension	 <ul style="list-style-type: none"> Lower FIRST MAIN ARM and tighten using allen wrench as much as possible and then loosen it a bit. Tension control: long nose plier or spanner Strong : octagon nut is close from brass shaft Weak : octagon nut is far from brass shaft Final Step: 3mm allen wrench Lower FIRST MAIN ARM as much as possible Loosen tension control bolt by pipe surface level <p>⚠ Avoid Hexagon nut broken</p>

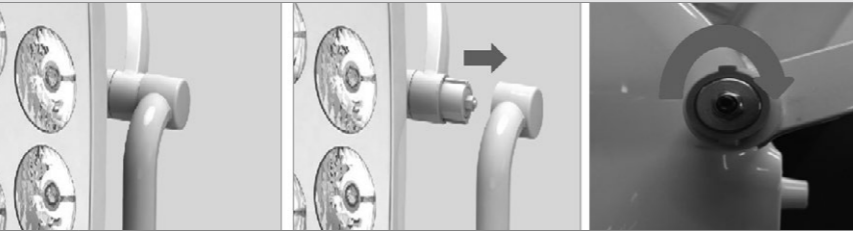
10.2 Mechanical troubleshooting

No.	Problem	Corrective action
2	Head (1 axle) tension control	 <ul style="list-style-type: none"> · Remove left and right handles · Adjust proper tension with long nose plier <p>⚠ Do not force excessively Be careful not to change the direction of the handle.</p>
3	Head (2 axle) tension control	 <ul style="list-style-type: none"> · Check the joint part of first head arm and second head arm. · Working Method: Make Head Arm direction to the front side, make sure the side of Head Arm Hole and internal bolt position. · Adjusting tension by 2mm allen wrench. <p>⚠ Do not force excessively</p>
4	Head (3 axle) tension control	 <ul style="list-style-type: none"> · Check the joint part of Second Head Arm Body. · Working Method: Check the hexagon bolt fixation by spinning Head · Adjusting tension by 1.5mm allen wrench. <p>⚠ Do not force excessively</p>

11. Disposal













- For environment and safety of human, wastes must be recycled or separated.
- The materials should be carefully separated.
- The electrical boards should be submitted to an appropriate recycling proceeding
- The cardboard box may be recycled with other paper products.
- Please contact the closest DENTIS branch or your supplier, if you have any questions about recycling of the device

12. Model designation

Head	Mount Type	Camera	Colour	Resin cover	Remote control	Adapter
C500	H=Head C=Chair W=Wall E=Ceiling M=Mobile	0 = None 1 = Camera(x30) 2=Camera(4K)	S=single M-Multi	0 = None 1 = Resin cover	A=None B=Remote control	0 = None 1 = Adapter

13. List of components

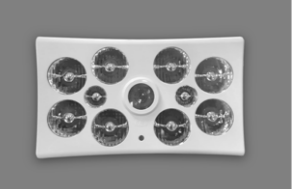
FIRST MAIN ARM	ELBOW JOINT & SECOND MAIN ARM	MOBILE SECOND ARM & VERTICAL ARM	
			
MOBILE BASE	CEILING COVER	WALL BRACKET	
			
CEILING MOUNT & VERTICAL ARM			
			
HANDLE	ADAPTER	REMOTE CONTROLLER (OPTIONAL)	C500 LIGHTHEAD (CAMERA OPTIONAL)
			

15. Manufacturer and Factory

Manufacturer, Factory : DENTIS MEDICAL DIVISION
6, Yuram-ro, Dong-gu, Daegu, Republic of Korea

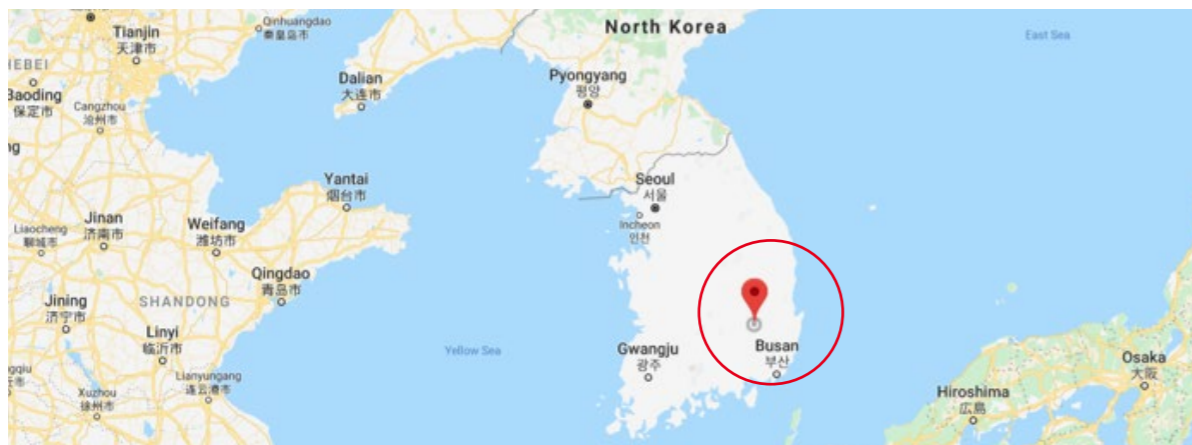

16. Europe Representative

Location of KTR Europe GmbH. Mergenthalerallee 77, 65760 Eschborn, Germany

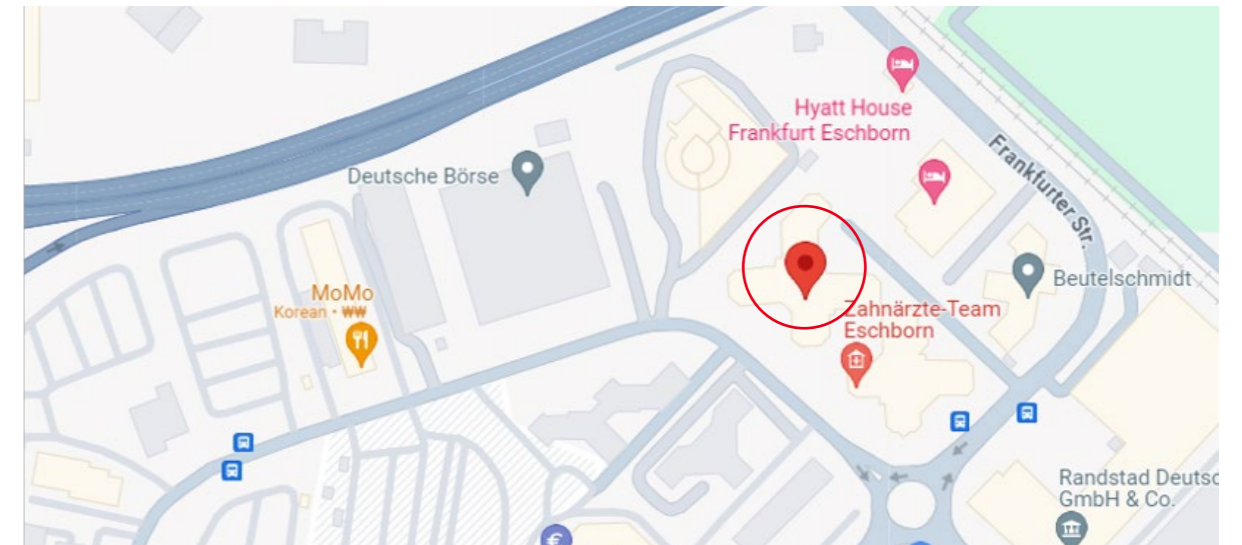



DENTIS

DENTIS Co., Ltd. (HEADQUARTERS) 87, Yuram-ro Dong-gu, Daegu, Republic of KOREA Tel +82-53-583-2804 Fax +82-53-583-2806
DENTIS MEDICAL DIVISION(FACTORY) 6, Yuram-ro, Dong-gu, Daegu, Korea Tel. +82-70-7730-4146 Email. luvis@luvis.co.kr

EL10IP-PM010