



Dental Light

# LUVIS | C300 C400



\* Be sure to read the manual before using this product.

<b>1</b>	03	<b>2</b>	04		
<b>Standards</b>		<b>Cautions and Warnings</b>			
<b>3</b>	08	<b>4</b>	09		
<b>Symbol</b>		<b>Introduction</b>			
<b>5</b> 13 <b>LIGHTHEAD specification</b> 5.1 Technical specification (In accordance with EN/ISO 9680) 5.2 Electrical specification (In accordance with EN 60601-1) 5.3 Mechanical specification		4.1 Intended use 4.2 General description 4.3 Environmental requirement 4.4 Safety information 4.5 Warranty regulation 4.6 Electromagnetic Compatibility			
		<b>7</b> 17 <b>Performance characteristic</b> 7.1 Adjusting the balancing of the ARM 7.2 Operating range of HEAD ARM 7.3 Operating range of MAIN ARM			
				<b>9</b> 24 <b>Maintenance</b>	
<b>8</b> 22 <b>Cleaning and Sterilization</b> 8.1 Cleaning the equipment 8.2 MAIN HANDLE AUTOMATIC CLEANING 8.3 MAIN HANDLE MANUAL CLEANING 8.4 MAIN HANDLE Sterilization		<b>12</b> 26 <b>Model designation</b>			
		<b>14</b> 28 <b>Manufacturer and Factory</b>			
<b>10</b> 25 <b>Troubleshooting</b> 10.1 General troubleshooting		<b>15</b> 29 <b>Europe Representative</b>			
<b>13</b> 27 <b>List of components</b>					

## 1. Standards

### \* Certification of DENTIS

- EN ISO 13485:2016
- Relevant EC Regulation: REGULATION (EU) 2017/745

### \* Applied Standards:

- EN ISO 15223-1:2016, Medical devices – Symbols to be used with medical device labels, labelling and information to be supplied – Part 1: General requirements
- EN 1041:2008/A1:2013, Information supplied by the manufacturer with medical devices
- EN ISO 13485:2016, Medical devices – Quality management systems – Requirements for regulatory purpose
- EN ISO 14971:2019, Medical devices – Application of risk management to medical devices
- EN 60601-1:2006+A2:2021, Medical electrical equipment – Part 1: General requirements for basic safety and essential performance
- EN 60601-1-2:2015, Medical electrical equipment – Part 1-2: General requirements for basic safety and essential performance - Collateral standard: Electromagnetic disturbances – Requirements and tests
- EN 60601-1-6:2010, Medical electrical equipment-Part 1-6: General requirements for basic safety and essential performance – Collateral Standard: Usability
- EN ISO 7010:2019, Graphical symbols – Safety colors and safety signs-Registered safety signs
- EN 62471:2008, Photo biological safety of lamps and lamps systems
- EN 62366-1:2015, Medical devices – Application of usability engineering to medical devices
- EN ISO 9680:2021, Dentistry – Operating lights
- IEC 62304:2006/A1:2015, Medical device software, Software life-cycle processes
- EN IEC 80601-2-60:2020, Medical electrical equipment – Part 2-60: Particular requirements for the basic safety and essential performance of dental equipment

## 2. Cautions and Warnings

**⚠ CAUTION(ATTENTION)** This ME Equipment is intended only for use in the professional health-care facility environment, e.g. public and private hospitals, specialized medical offices, etc. This ME Equipment is intended for direct use on operation theatres and nearby HF surgical equipments, where the intensity of EM DISTURBANCES complies with the applicable standards. For further instructions please follow the chapter "Electromagnetic compatibility" of the User's Manual.

- Cet équipement ME est destiné uniquement à être utilisé dans l'environnement des établissements de santé professionnels, p. ex. hôpitaux publics et privés, cabinets médicaux spécialisés, etc. Cet équipement ME est destiné à être utilisé directement sur les salles d'opération et les équipements chirurgicaux HF situés à proximité, où l'intensité des perturbations électromagnétiques est conforme aux normes applicables. Pour de plus amples instructions, veuillez suivre le chapitre « Compatibilité électromagnétique » du Manuel de l'utilisateur.

**⚠ CAUTION(ATTENTION)** If this ME Equipment is lost or degraded the performance due to EM DISTURBANCES, result in improper operation and degradation of the performance.

- Si cet équipement est perdu ou dégradé en raison de perturbations électromagnétiques, il en résulte un mauvais fonctionnement et une dégradation de la performance.

**⚠ CAUTION(ATTENTION)** All cables and maximum lengths of Coaxial cables that are replaceable by the DENTIS. and that are likely to affect compliance of the this ME Equipment with the requirements of EMC(Electro-Magnetic compatibility).

Do not modify this ME Equipment.

- Tous les câbles et longueurs maximales des câbles coaxiaux remplaçables par DENTIS et susceptibles d'affecter la conformité de cet ÉQUIPEMENT ME aux exigences de la CEM (Compatibilité Électro-Magnétique).

Ne modifiez pas cet ÉQUIPEMENT ME.

**⚠ CAUTION(ATTENTION)** The EMISSIONS characteristics of this equipment make it suitable for use in industrial areas and hospitals (CISPR 11 Class A). If it is used in a residential environment (for which CISPR 11 Class B is normally required) this equipment might not offer adequate protection to radio-frequency communication services. The user might need to take mitigation measures, such as relocating or re-orienting the equipment.

- Les caractéristiques d'ÉMISSIONS de cet équipement le rendent adapté à une utilisation dans des zones industrielles et des hôpitaux (CISPR 11 classe A). S'il est utilisé dans un environnement résidentiel (où la classe B CISPR 11 est normalement requise), cet équipement pourrait ne pas offrir une protection adéquate aux services de communication radiofréquence. L'utilisateur pourrait devoir prendre des mesures d'atténuation, telles que déplacer ou réorienter l'équipement.

**⚠ WARNING(AVERTISSEMENT)** Use of this ME Equipment adjacent to or stacked with other equipment should be avoided because it could result in improper operation. If such use is necessary, this equipment and the other equipment should be observed to verify that they are operating normally.

- L'utilisation de cet ÉQUIPEMENT ME à proximité ou empilé avec d'autres équipements doit être évitée car cela pourrait entraîner un fonctionnement incorrect. Si une telle utilisation est nécessaire, cet équipement et les autres équipements doivent être surveillés pour vérifier qu'ils fonctionnent normalement.

**⚠ WARNING(AVERTISSEMENT)** Use of all cables and coaxial cables other than those specified or provided by DENTIS. of this ME Equipment could result in increased electromagnetic emissions or decreased electromagnetic immunity of this equipment and result in improper operation.

- L'utilisation d'accessoires, de transducteurs et de câbles autres que ceux spécifiés ou fournis par DENTIS pour cet ÉQUIPEMENT ME pourrait entraîner une augmentation des émissions électromagnétiques ou une diminution de l'immunité électromagnétique de cet équipement, et entraîner un fonctionnement incorrect.

**⚠ WARNING(AVERTISSEMENT)** High frequency equipment and portable RF communications equipment (including peripherals such as antenna cables and external antennas) should be used no closer than 30 cm to any part of the C300/C400, including cables specified by DENTIS. Otherwise, degradation of the performance of this equipment could result.

- L'équipement haute fréquence et l'équipement de communication RF portable (y compris les périphériques comme les câbles d'antenne et les antennes externes) ne doivent pas être utilisés à moins de 30 cm de toute partie du C300/C400, y compris les câbles spécifiés par DENTIS. Sinon, il pourrait en résulter une dégradation de la performance de cet équipement.

**⚠ WARNING(AVERTISSEMENT)** The instructions given in this document must be followed when handling the product. Failure to do so may endanger the safety of the installers or users. As well as specific information on operating the entire product and conducting preventive maintenance, are provided in the USER'S MANUAL. For further information, please contact our sales network or our local network.

- Les instructions données dans ce document doivent être suivies lors de la manipulation du produit. Ne pas le faire peut mettre en danger la sécurité des installateurs ou des utilisateurs. Des informations spécifiques sur le fonctionnement du produit dans son ensemble et sur l'exécution de la maintenance préventive sont fournies dans le MANUEL DE L'UTILISATEUR. Pour plus d'informations, veuillez contacter notre réseau de vente ou notre réseau local

**⚠ WARNING(AVERTISSEMENT)** The electrical connections must be performed by a qualified technician only.

The electrical installation must be planned, performed and inspected by electrical engineers.

- Les connexions électriques doivent être effectuées uniquement par un technicien qualifié.

L'installation électrique doit être planifiée, réalisée et inspectée par des ingénieurs électriciens.

**⚠ WARNING(AVERTISSEMENT)** The LIGHTHEAD is designed to operate at AC 100 - 240V 50 - 60Hz(ADAPTER), AC 12 - 18V 50/60Hz(Without ADAPTER). Higher or lower voltages may affect the light intensity and operating life of the LEDs.

Luvis(C300/C400) is class I equipment for use with ADAPTER. In order to avoid the risk of an electric shock, the equipment must be connected to a mains supply with PE(protective earth).

- Le LIGHTHEAD est conçu pour fonctionner à AC 100 - 240 V 50 - 60Hz (ADAPTER), AC 12 - 18 V 50/60Hz (Sans ADAPTATEUR). Des tensions plus ou moins fortes peuvent affecter l'intensité lumineuse et la durée de vie utile des DEL.

Luvis (C300/C400) est un équipement de classe I à utiliser avec ADAPTATEUR. Afin d'éviter le risque de choc électrique, l'équipement doit être raccordé à une alimentation principale avec PE (terre protectrice).

**⚠ WARNING(AVERTISSEMENT)** A main control switch must be installed for turning the system power-off. Damaged wire insulation may result in the risk of electric shock.

- Un interrupteur de commande principal doit être installé pour éteindre le système.

L'isolation des fils endommagés peut entraîner un risque de choc électrique.

**⚠ WARNING(AVERTISSEMENT)** The power supplies may be installed and connected only by an electrician or a DENTIS authorized service agent.

- Les alimentations électriques ne peuvent être installées et connectées que par un électricien ou un agent de service autorisé par DENTIS.

**⚠ WARNING(AVERTISSEMENT)** This product may only be repaired and special assembly work may only be carried out by DENTIS or a company that has been authorized by DENTIS.

- Ce produit ne peut être réparé et des travaux d'assemblage spéciaux ne peuvent être effectués que par DENTIS ou une entreprise autorisée par DENTIS.

**⚠ WARNING(AVERTISSEMENT)** Check the polarity of all electrical connections before turning on the power.

- Vérifiez la polarité de toutes les connexions électriques avant d'allumer l'alimentation.

**⚠ WARNING(AVERTISSEMENT)** The LIGHTHEAD brakes are adjusted during installation. Like all mechanical parts, the brakes are subject to wear. Check the condition of the mounting surface.

- Les freins de la TÊTE D'ÉCLAIRAGE sont ajustés lors de l'installation. Comme toutes les pièces mécaniques, les freins sont sujets à l'usure. Réajustez les freins si la TÊTE D'ÉCLAIRAGE ne reste plus stable dans toutes les positions. Vérifiez l'état de la surface de montage.

**⚠ WARNING(AVERTISSEMENT)** Do not look directly into light source(LED).

- Ne regardez pas directement la source lumineuse (LED)

**⚠ WARNING(AVERTISSEMENT)** The operation and safety of the device may be affected by the removal of certain components during servicing operations.

- Le fonctionnement et la sécurité de l'appareil peuvent être affectés par le retrait de certains composants lors des opérations d'entretien.

**⚠ WARNING(AVERTISSEMENT)** All the information in this manual has been checked out carefully and discerned as accurate one at the time of publication.

However, DENTIS takes no responsibilities of the results caused by default, omission, or misuse of it.

- Toutes les informations contenues dans ce manuel ont été soigneusement vérifiées et jugées exactes au moment de la publication. Cependant, DENTIS décline toute responsabilité pour les résultats causés par des défauts, des omissions ou une mauvaise utilisation de celles-ci.

**⚠ WARNING(AVERTISSEMENT)** DENTIS has rights to modify the product itself or specifications of the product without any prior notice, as well as rights not to renew that modification on this manual.

- DENTIS se réserve le droit de modifier le produit lui-même ou les spécifications du produit sans préavis, ainsi que le droit de ne pas renouveler cette modification dans ce manuel.

**⚠ WARNING(AVERTISSEMENT)** The circuit of medical device must be installed in the state with the means to electrically separate with in all poles from the POWER SUPPLY.

- Le circuit du dispositif médical doit être installé dans un état permettant une séparation électrique de tous les pôles de l'ALIMENTATION.

**⚠ WARNING(AVERTISSEMENT)** Do not turn on/off by reapting the Main Power Switch. It cause of failure.

- Ne pas allumer/éteindre en récoltant le commutateur principal d'alimentation. C'est la cause de l'échec.

**⚠ WARNING(AVERTISSEMENT)** Do not directly illuminate patient's eye more than 5 seconds.

- N'éclairez pas directement l'œil du patient plus de 5 secondes.

















**⚠ WARNING(AVERTISSEMENT)** Potential need of protection either for eye or face, or both, for individuals with sensitivity to strong light sources, such as those taking a photosensitizing drug that can accumulate in eye tissue and those with certain eye diseases or photodermatoses.







- Besoin potentiel de protection des yeux ou du visage, ou des deux, pour les personnes sensibles à des sources lumineuses fortes, comme celles qui prennent un médicament photosensibilisant qui peut s'accumuler dans les tissus oculaires et celles qui souffrent de certaines maladies oculaires ou de photodermatoses.

**⚠ WARNING(AVERTISSEMENT)** When using the Adapter type, be sure to make easy connect and disconnect the power cord.

- Lorsque vous utilisez le type Adaptateur, assurez-vous de faciliter la connexion et la déconnexion du cordon d'alimentation.

### 3. Symbol

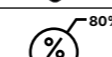
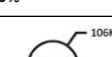
Symbol (Symbole)	Meaning (Signification)	Remark (Remarque)
	<b>CE Mark</b> The device bears the CE mark and complies with the requirements of Regulation (EU) MDR 2017/745 for medical device. - L'appareil porte le marquage CE et est conforme aux exigences du Règlement (UE) MDR 2017/745 relatif aux dispositifs médicaux.	④, ⑤, ⑥
	MEDICAL – GENERAL MEDICAL EQUIPMENT AS TO ELECTRICAL SHOCK, FIRE AND MECHANICAL HAZARDS ONLY IN ACCORDANCE WITH [ANSI/AAMI ES60601-1:2005/(R)2012 and A1:2012, C1:2009/(R)2012 and A2:2010/(R)2012, CAN/CSA C22.2 No. 60601-1:14] - MATÉRIEL MÉDICAL – GÉNÉRALITÉS CONCERNANT LES CHOCS ÉLECTRIQUES, LES INCENDIES ET LES DANGERS MÉCANIQUES SEULEMENT CONFORMÉMENT AUX [ANSI/AAMIES 60601-1:2005/(R)2012 et A1:2009/(R)2012/(R)2012, CAN/CSA C222 No. 60-114]	④, ⑤, ⑥
	Recommendation - Recommandation	⑤
	Protective earth (ground) - Terre de protection	②
	Alternating current - Courant alternative	②
	Stand-by - Mode veille	③
	Do not throw away with general household waste - Ne pas jeter avec les déchets ménagers ordinaires	④, ⑤, ⑥
	Caution - ATTENTION	⑤
	Warning - AVERTISSEMENT	⑤
	Operating instructions - Suivre les instructions d'utilisation	⑤
	Follow instructions for use - Action obligatoire générale	⑥
	General mandatory action - Pousser interdit	①
	Pushing prohibited - GARDER À L'ÉCART DE LA PLUIE	①
	KEEP AWAY FROM RAIN - NE PAS UTILISER DE CROCHETS À MAIN	④
	USE NO HAND HOOKS - FRAGILE, MANIPULER AVEC PRÉCAUTION	④
	FRAGILE, HANDLE WITH CARE - TOUJOURS GARDER DANS CE SENS	④
	THIS WAY UP	④

Symbol (Symbole)	Meaning (Signification)	Remark (Remarque)
	Do not build up more than 5 boxes - Ne pas empiler plus de 5 boîtes	④
	Manufacturer - Fabricant	④, ⑤, ⑥
	Europe Representative - Représentant en Europe	⑤, ⑥
	Date of manufacture - Date de fabrication	⑤, ⑥
	Temperature between 0 - 40°C - Température entre 0 - 40°C	④
	Humidity between 0 - 80%RH - Humidité entre 0 - 80 %HR	④
	Atmospheric pressure between 80Kpa – 106Kpa - Pression atmosphérique entre 80 kPa – 106 kPa	④
	Recycling - Recyclage	④, ⑤

No.	Location (Emplacement)
①	Marking on the outside of ME EQUIPMENT - Marquage à l'extérieur de l'ÉQUIPEMENT ME
②	Marking on the inside of ME EQUIPMENT - Marquage à l'intérieur de l'ÉQUIPEMENT ME
③	Marking on the controls of ME EQUIPMENT - Marquage sur les commandes de l'ÉQUIPEMENT ME
④	Marking on the packing label of ME EQUIPMENT - Marquage sur l'étiquette d'emballage de l'ÉQUIPEMENT ME
⑤	Marking on the manual of ME EQUIPMENT - Marquage sur le manuel de l'ÉQUIPEMENT ME
⑥	Marking on the label of ME EQUIPMENT - Marquage sur l'étiquette de l'ÉQUIPEMENT ME

### 4. Introduction

#### 4.1 Intended use

- Dental Light is intended to be used to provide visible illumination of the dental surgical area or the patient during dental surgery, diagnosis and treatment.
- Classification under the provision of REGULATION (EU) 2017/745 (MDR) : Class I  
- Dental Light is classified as a Class I device.
- Classification under the provision of FDA (U.S. Food and Drug Administration) : Class I  
- Dental Light is classified as a Class I device.
- Form of protection against electric shock : Class I (ADAPTER)

- Degree of protection against flammability
  - Dental Light is classified as a device not suitable to be used in a potentially flammable environment.
  - Do not use near flammable materials.
- Method(s) of sterilization or disinfection recommended by the manufacturer.
  - The HANDLE should be cleaned with cloths
  - The MAIN HANDLE should be sterilized with sterilizer regularly to prevent infection.
- Mode of operation
  - Classification of Dental Light : continuous operation.

## 4.2 General description

- The user must ensure that the device works properly and is in a satisfactory condition before each use.
- This DENTIS device is intended only for use in the field of medical. It is impermissible to use the device for a purpose for which it was not intended.
- "Proper Use" includes following all the instructions for use and ensuring that all inspections and service tasks are performed.
- Apply and meet the overarching guidelines and/or national laws, national regulations and the rules of technology for medical devices applicable for startup and use of the device for the intended purpose.
- The user must observe the following:
  - Only use properly operating equipment.
  - Protect himself or herself and third parties from danger.
  - Avoid contamination from the device.
- During use, the following national regulations must be observed:
  - he applicable health and safety regulations.
  - The applicable accident prevention regulations.
- To ensure that device maintains their value and are always ready for use, they must be serviced once a year as recommended.
- Before using the products, You must receive training by authorized person of the DENTIS.
- The safety checks must be performed every year.
- Repair and service of the device is authorized only to those who meet the requirements below:
  - Technicians of authorized dealers specially trained by DENTIS.
  - The trained technicians of DENTIS branches.

## 4.3 Environmental requirement

- |   |  |
|---|--|
| · Conditions of the usage environment             | · Conditions of storage and transportation environment |
| - Temperature : 0 – 40°C                          | - Temperature : 0 - 40 °C                              |
| - Relative Humidity : 30 – 90 %                   | - Relative Humidity : 0 - 80 %                         |
| - Atmospheric pressure : 0 – 2,000 m (106–80 Kpa) | - Atmospheric pressure: 0 - 2,000 m (106 – 80 Kpa)     |

## 4.4 Safety information

- Dental Light as a medical device complies with the safety regulation EN/IEC 60601-1, EN/ISO 9680.
- Accessory equipment connected to the analog and digital interfaces must be certified according to the respective EN/IEC standards (e.g. EN/ISO 9680 for Dentistry-Operating lights and EN/IEC 60601-1 for medical equipment).
- Furthermore all configurations shall comply with the system standard EN/IEC 60601-1, EN/ISO 9680. Everybody who connects additional equipment to the signal input part or signal output part configures a medical system,

and is therefore responsible that the system complies with the requirements of the system standard EN/IEC 60601-1.

- If in doubt, consult the technical service department or your local representative
- For EU Countries

Europe Representative  
KTR Europe GmbH  
Mergenthalerallee 77, 65760 Eschborn, Germany



- Safety is everyone's obligation and responsibility.
- The safe use of this product is related to everyone such as installer, user, operator and equipment's manager.
- It must read and learn this user's manual is compulsory before installation, using, cleaning, fixing or operation of this product or its accessories. Pay particular attention and be familiar with warning symbols about safety.
- If do not follow safety direction of this manual, you can get injured or accident when you operate this product. After read carefully and understand this manual, use this product.
- This manual is in keep a place where you can find easily.

## 4.5 Warranty regulation

- DENTIS warrants all products against defects in materials or workmanship for two year from time of delivery.
- DENTIS's sole obligation under the warranty is to provide parts for the repair, or at its option, to provide the replacement product (excluding labor).
- The buyer shall have no other remedy. All special, incidental, and coincidental damages are excluded.
- Written notice of breach must be given to DENTIS within the warranty period.
- The warranty does not cover damage resulting from improper installation or maintenance, accident or misuse.
- The warranty does not cover damage resulting from the use of cleaning, disinfecting or sterilization chemicals and processes.
- The Failure to follow instructions provided in the DENTIS Instructions for Use (operation and maintenance instructions) may void the warranty.
- LED PCB ASS'Y is covered under 60,000 hrs warranty.

## 4.6 Electromagnetic Compatibility

### 4.6.1 Emission

This ME equipment is intended for use in Professional healthcare facility environment.		
Emission test	Compliance	Guidance
Conducted Disturbance CISPR 11(EN 55011)	Complies (Group 1, Class A)	This ME equipment uses RF energy only for its internal function. Therefore, its RF emissions are very low and are not likely to cause any interference in nearby electronic equipment.
Radiated Disturbance CISPR 11(EN 55011)		
Harmonic current IEC 61000-3-2	Complies	This ME equipment is suitable for use in all establishments other than domestic premises and those directly connected to the public low-voltage power supply network that supplies buildings used for domestic purposes.
Voltage fluctuations and flicker IEC 61000-3-3	Complies	

#### 4.6.2 Immunity

This ME equipment is intended for use in Professional healthcare facility environment.				
Immunity test	EN 60601-1-2:2015		Compliance	
Electrostatic Discharge(ESD) IEC 61000-4-2	Direct : ± 8 kV Contact ± 2 kV, ± 4 kV, ± 8 kV, ± 15 kV Air Indirect : ± 8 kV HCP/VCP		Complies	
Radio Frequency Electromagnetic Fields IEC 61000-4-3	3 V/m @ 80 MHz ~ 2.7 GHz 80 % AM at 1 kHz		Complies	
Proximity fields from RF wireless communications equipment IEC 61000-4-3	<b>Frequency (MHz)</b>	<b>Modulation</b>	<b>Immunity Level (V/m)</b>	
	385	**Pulse Modulation: 18 Hz	27	
	450	*FM ± 5Hz deviation: 1 kHz sine	28	
	710 745 780	**Pulse Modulation: 217 Hz	9	
	810 870 930	**Pulse Modulation: 18 Hz	28	
	1720 1845 1970	**Pulse Modulation: 217 Hz	28	
	2 450	**Pulse Modulation: 217 Hz	28	
	5 240 5 500 5 785	**Pulse Modulation: 217 Hz	9	
	** The carrier shall be modulated using a 50 % duty cycle square wave signal. * As an alternative to FM modulation, 50 % pulse modulation at 18 Hz may be used because while it does not represent actual modulation, it would be worst case.			Complies
	Fast Transients IEC 61000-4-4	<b>Voltage</b>	<b>AC/DC power ports</b>	<b>Signal ports</b>
	Test voltage	± 2 kV	± 1 kV	
- 100 kHz repetition frequency			Complies	
Surges IEC 61000-4-5	<b>Voltage</b>	<b>Power lines</b>		
	Test voltage	Line to Line : ± 0.5 kV, ± 1 kV Line to ground: ± 0.5 kV, ± 1 kV, ± 2 kV		
RF Continuous Conducted IEC 61000-4-6	3 V @ 0.15 MHz ~ 80 MHz 6 V @ in ISM bands between 0.15 MHz and 80 MHz 80 % AM at 1 kHz		Complies	
Power Frequency Magnetic Fields IEC 61000-4-8	30 A/m @ 50 Hz or 60 Hz		Complies	
Voltage Dips, Interruptions, and Variations IEC 61000-4-11	• Voltage Dips 0 % UT; 0,5 cycle At 0°, 45°, 90°, 135°, 180°, 225°, 270° and 315° 0 % UT; 1 cycle and 70 % UT; 25/30 cycles Single phase: at 0°			
	• Voltage Interruptions 0 % UT; 250/300 cycle			
	• Voltage Variations			
	<b>Frequency (Hz)</b>	<b>Ranges</b>		
50	49, 50, 51			
60	59, 60, 61			

## 5. LIGHTHEAD specification

### 5.1 Technical specification (In accordance with EN/ISO 9680)

· STANDARD SPECIFICATION

Specifications	Unit	LUVIS C300/C400		Remark
		Transparent Lens Cover	Violet Lens Cover	
Central illuminance	Max.	lx	30,000	25,000
Ec (@700mm)	Irradiance (Ee)	W/m <sup>2</sup>	100	85
Illuminance in patient's eyes	lx	≤ 1,000		
Hard shadow	mm	12 × 8		
Focal Distance	mm	700		
Size of area (inside pattern A)	mm	65 × 40		
Size of area (outside pattern B)	mm	90 × 60		
Pattern size	mm	150 × 90		Horizontal Axis
Color temperature	K	4,300	5,000	
Color fidelity index (Ra, Rf)	N/A	85	90	

\* Optical values are measured with a tolerance of ±10%

### 5.2 Electrical specification (In accordance with EN 60601-1)

· TECHNICAL DATA

Content	LUVIS C300/C400	Remark
Input	AC 12 – 18V, 2A @50/60 Hz	Chair Type
	AC 100 – 240 V, 50/60 Hz 1.5A	ADAPTER Type
Power Consumption	Chair Type : 13VA / ADAPTER Type : 31VA	

⚠ Please use be connected to a chair unit that can limit the power supply.  
If the power supply is not a dental chair unit, use the special ADAPTER, which Must provided by the DENTIS

### 5.3 Mechanical specification

Specifications	Size(mm)	Weight(kg)	Remark
LED HEAD	208 × 180 × 80	1.6	HEAD
MAIN ARM		4.4	FIRST MAIN ARM + SECOND MAIN ARM
WALL BRACKET		2.3	
CEILING VERTICAL ARM	Φ42.7×733	5	
CEILING COVER & BRACKET	Φ500×50	1.15	
CEILING MOUNTING SET	-	13.36	GUIDE BRACKET + FIX BRACKET + STUD BOLT

## 6. USE

### 6.1 HEAD CONTROLLER

· The LED DENTAL LIGHT can be controlled using the DIMMING DIAL

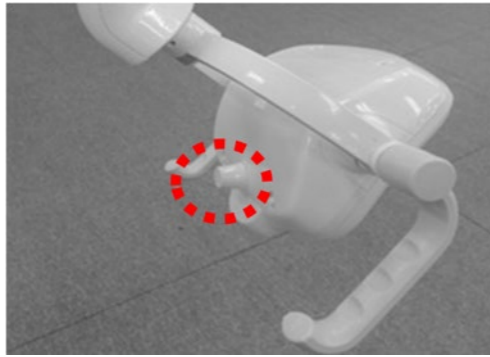

Illumination Function		
	DIMMING DIAL	<ul style="list-style-type: none"><li>- Dimming control using a dial</li><li>- Clockwise : Illuminance rises</li><li>- Anticlockwise : Illuminance drop</li></ul>

### 6.3 SENSOR

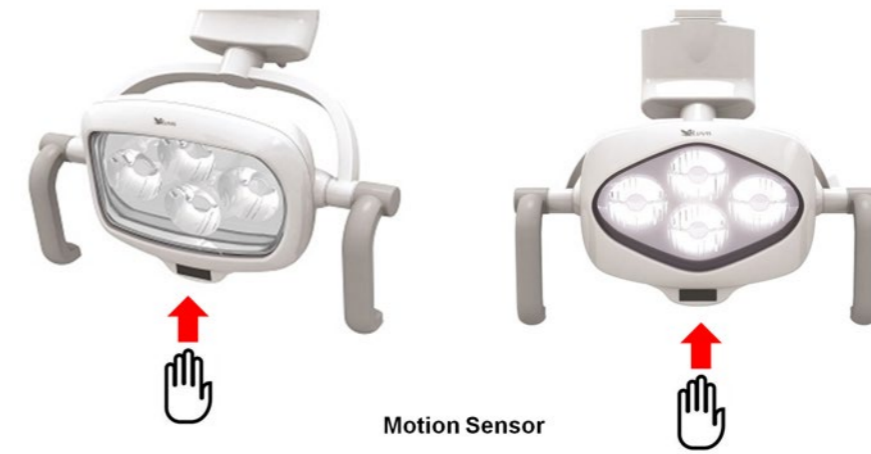

- ON/OFF(1 seconds)
- Adjust illuminance(over than 2 seconds)

### 6.2 HANDLE

⚠ Check the detachable way before using the product.

Check for cracks.

Make sure the correct position on the HANDLE.



#### Mounting HANDLE

- Insert the handle to fixed the mount .
- Check Rotate to the left or right

#### Remove the HANDLE

- Pull the HANDLE to remove

## 7. Performance characteristic

### 7.1 Adjusting the balancing of the ARM

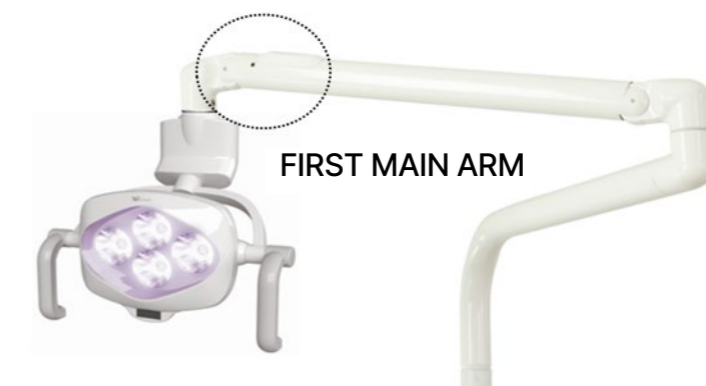
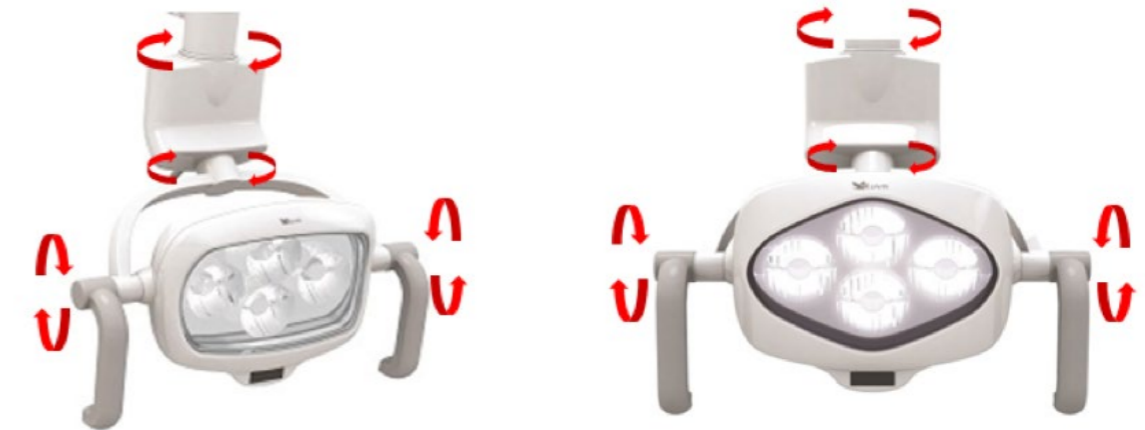

⚠ The FIRST MAIN ARM contains a powerful spring. When the LIGHTHEAD is dismantled, the FIRST MAIN ARM can suddenly jump up and may cause serious injury. Make sure the apparent weight of the LIGHTHEAD is the same when raised and lowered and that it is stable in any position.

### 6.4 Positioning

Positioning the the C300/C400 LIGHTHEAD	
<p>·Use the HANDLE to position the C300/ C400 LIGHTHEAD before the operation.</p> <p>·This HANDLE can be removed for sterilization.</p>	<p>·Recommended distance : 700mm</p>
<div style="display: flex; flex-direction: column; align-items: center;"> <div style="text-align: center;"> <p>d 75%</p> </div> <div style="display: flex; justify-content: space-around; width: 100%;"> <div style="text-align: center;"> <p>d 50%</p> </div> <div style="text-align: center;"> <p>d 10%</p> </div> </div> </div>	

## 7.2 Operating range of HEAD ARM

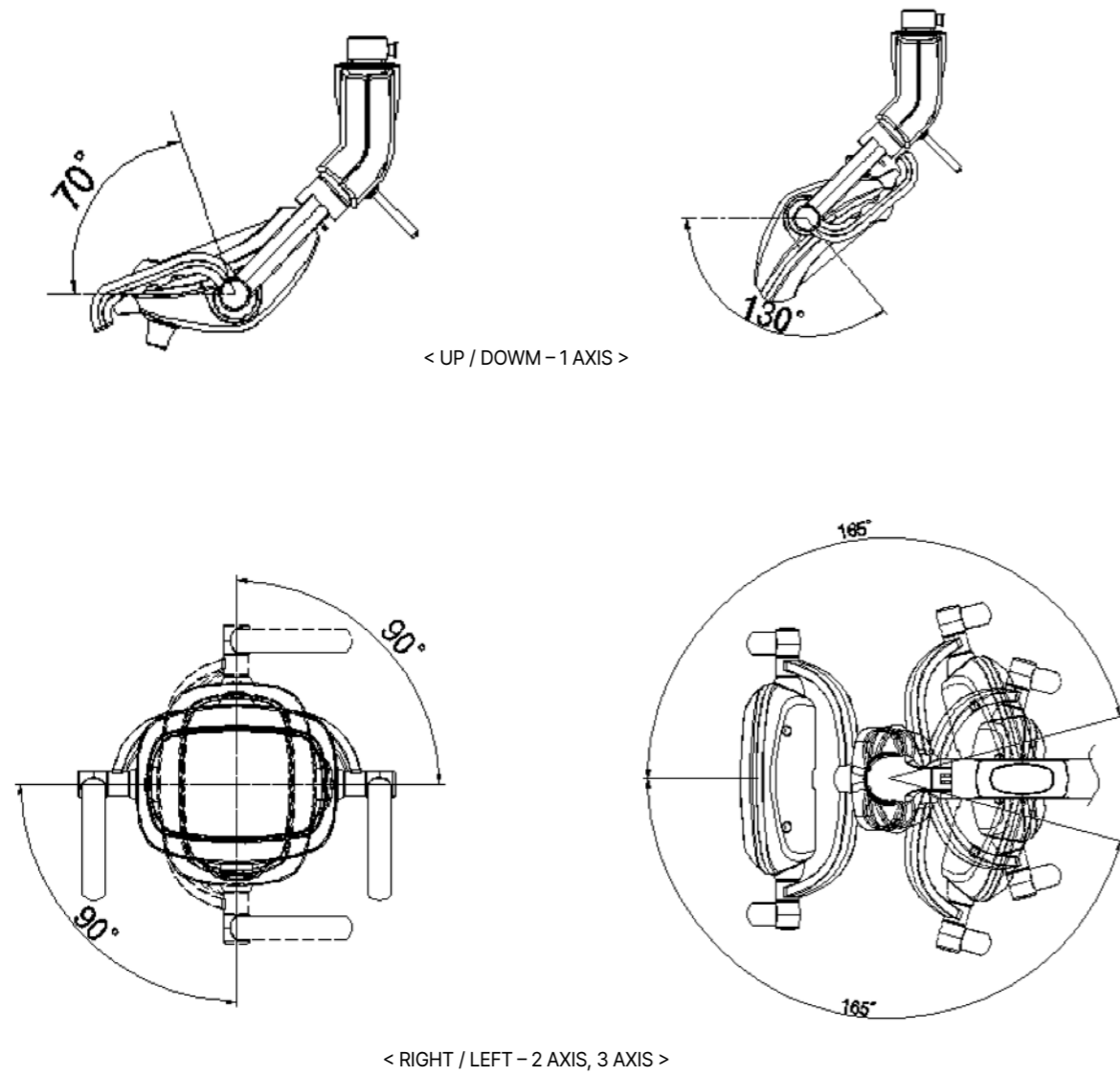

⚠ If this device is operated beyond the indicated angles, it can be damaged. During positioning, eventual collisions between the LIGHTHEAD, SPRING ARMS and other devices must be avoided.

⚠ This image was constructed to demonstrate the product's operating range. The image may differ from the actual product.

## 7.3 Operating range of MAIN ARM

CHAIR TYPE

(Unit : mm)

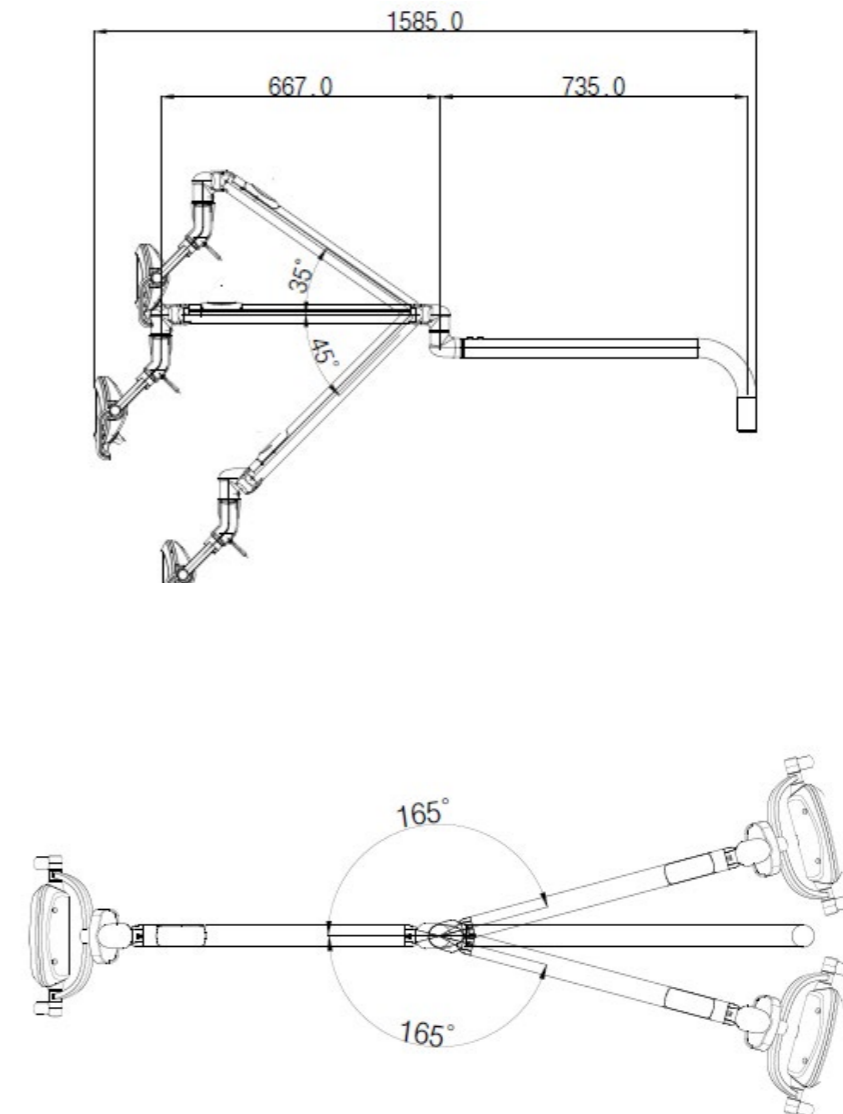

⚠ Do not place things on or hang on FIRST MAIN ARM.

⚠ If this device is operated beyond the indicated angles, it can be damaged.

### WALL TYPE

(Unit : mm)

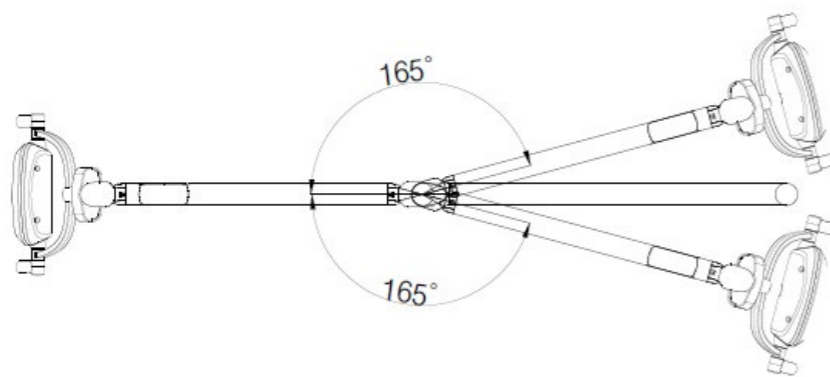
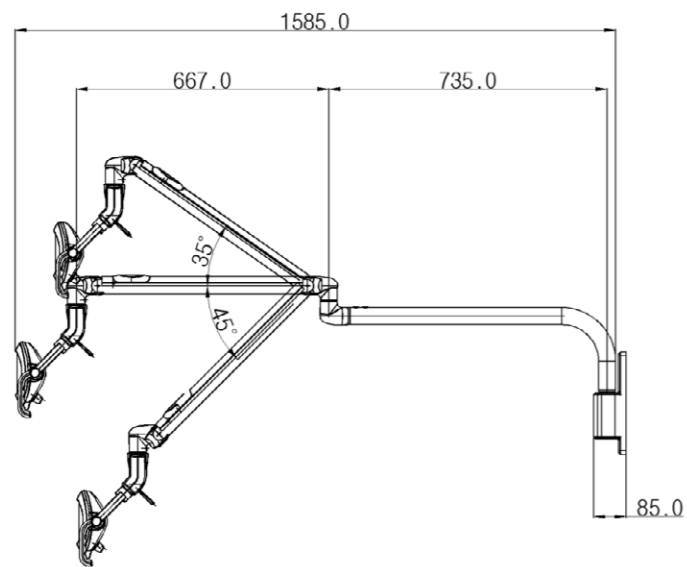

⚠ Do not place things on or hang on FIRST MAIN ARM.

⚠ If this device is operated beyond the indicated angles, it can be damaged..

### CEILING TYPE

(Unit : mm)

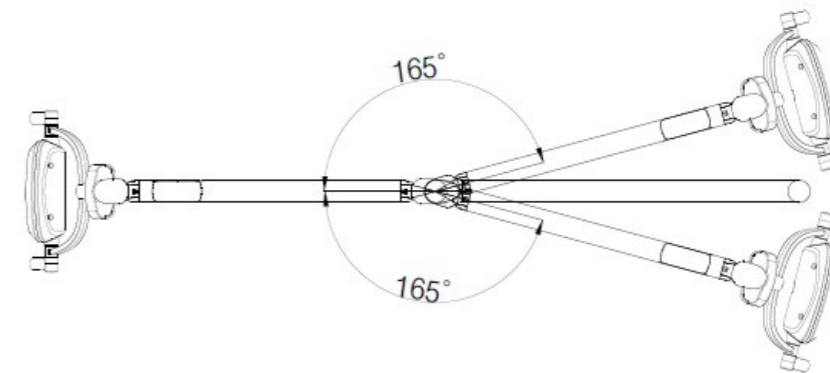
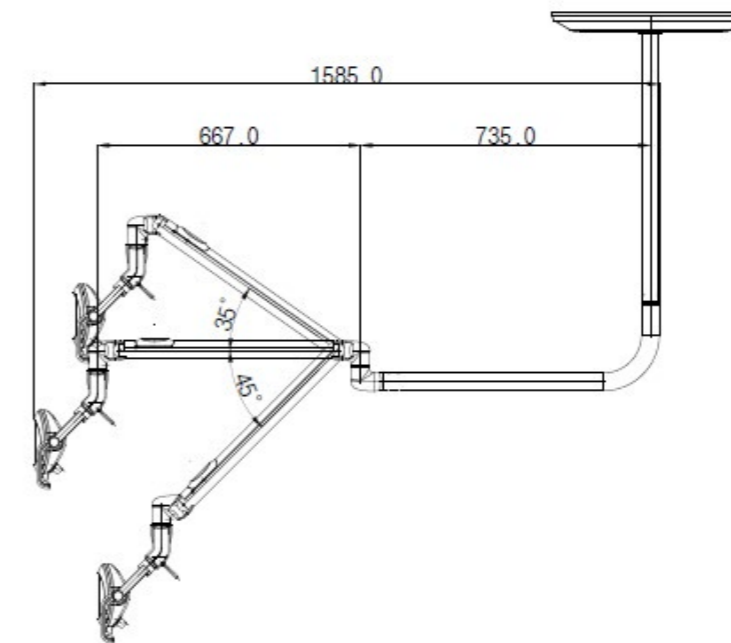

⚠ Do not place things on or hang on FIRST MAIN ARM.

⚠ If this device is operated beyond the indicated angles, it can be damaged.

## 8. Sterilization and Cleaning

**⚠** Cleaning and sterilization procedures vary from facility to facility and therefore it is not possible to specify a single procedure. The user should contact a specialist in the hospital and apply the recommended procedures according to the product. If you have any questions about the compatibility of your medication, please contact the DENTIS Customer Center.

The treatment level required for cleaning and disinfection of the MAIN HANDLE is a low level of disinfection. It is classified as non-critical devices with a low risk of infection, except for the use of sterilizable handles.

Contact your place of purchase in case of failure or damage.

**⚠** The use of cleaning agents containing the following substances is not permitted.  
- High concentrations of organic and inorganic acids and chlorinated hydrocarbons

### 8.1 Cleaning the equipment

**⚠** Before cleaning turn off the power and wait until LIGHTHEAD is sufficiently cooled.  
Wear gloves when cleaning and disinfecting.  
Do not spray cleaning and disinfectant directly into the LIGHTHEAD.

- Make sure that the system is powered off and the LIGHTHEAD is sufficiently cooled.
- Prepare cleaning agents and disinfectants. For cleaning agents, follow the manufacturer's instructions for use.
- Moisten a clean, lint-free, soft cloth with cleaning solution and remove excess moisture.
- Clean the area using a cloth soaked with cleaning agent.
- Clean the device using a cloth soaked with clean water.
- Wipe all surfaces with a clean, dry cloth to remove any residue.
- Make sure all cleaning and disinfectant residues have been removed before using the light.

### 8.2 MAIN HANDLE AUTOMATIC CLEANING

- After the treatment, remove the MAIN HANDLE from the dental lamp.
- Remove visible foreign substances using a soft brush and cloth in warm water flowing through the MAIN HANDLE for at least 1 minute.
- Place the MAIN HANDLE in the cleaning equipment and carry out the cleaning using an enzyme detergent according to the following cleaning conditions.

No.	Condition	Temperature(°C)	Minimum time(Min)
1	Pre-cleaning	20-40	1
2	Cleaning	20-40	5
3	Cleaning	20-40	2
4	Rinsing	20-40	10
5	Rinsing	20-40	10
6	Dry	50-70	90

- Remove the MAIN HANDLE from the cleaning equipment and ensure that the cleaning is complete.
- Check for foreign substances left inside and outside the MAIN HANDLE, if it is necessary, repeat the cleaning process
- Protect the cleaned and dried MAIN HANDLE from re-contamination.

### 8.3 MAIN HANDLE MANUAL CLEANING

- After the treatment, remove the MAIN HANDLE from the dental lamp.
- Immerse the MAIN HANDLE in the washing tank for at least 5 minutes in the diluted enzyme detergent. (Follow the manufacturer's instructions for use of the cleaner.)
- To prevent blood or foreign substances from drying out, soak the separated MAIN HANDLE in distilled water or tap water for 15 minutes to remove any foreign substances, then clean it with a soft brush and a lint-free cloth.
- Check inside and outside of the MAIN HANDLE for debris, and repeat cleaning if any debris remains.
- Rinse thoroughly with clean water and wipe clean with a lint-free cloth to dry.
- Protect the cleaned and dried main handle from re-contamination

### 8.4 MAIN HANDLE Sterilization

**⚠** Do not allow foreign substances to enter the MAIN HANDLE during sterilization. MAIN HANDLE is guaranteed for up to 100 sterilization cycles when the same sterilization conditions are applied.  
In the case of MAIN HANDLE, sterilization may cause wear, cracks, and discoloration. If these signs are detected, stop using the handle and replace it.  
The MAIN HANDLE being stored must be kept clean and sterile before use.  
If you are not wearing a sterile suit, be careful and do not touch the sterilized MAIN HANDLE.

- Sterilize the cleaned MAIN HANDLE according to the process below.
- Make sure the MAIN HANDLE is clean, wrap the HANDLE in sterile packaging (double packaging or equivalent) and seal it.
- When putting the MAIN HANDLE into the sterilizer, make sure that the hole is facing down to allow water to flow down.
- Place the MAIN HANDLE in the Pressurized Steam Sterilizer (AUTO CLAVE) and proceed with the sterilization cycle according to the sterilization conditions. Using chemical sterilization is prohibited
- Follow the sterilizer manufacturer's instructions and sterilization conditions of your country.
- When storing after sterilization, store in a tray in a sterile packaging material.(room temperature storage)

Sterilization Condition	
<ul style="list-style-type: none"> <li>· Operating Condition               <ul style="list-style-type: none"> <li>- Temperature : 132 °C</li> <li>- Pressure : 160 ± 50kPa (1.6 ±0.5 kgf/cm<sup>2</sup>)</li> <li>- Time : 10 min</li> <li>- Dry : 16 min</li> </ul> </li> </ul>	 <b>Autoclave</b>
Sterile Packaging	
<ul style="list-style-type: none"> <li>· Sterile Clothing               <ul style="list-style-type: none"> <li>- KIMGUARD sterile clothing</li> <li>- Model : KC500</li> </ul> </li> </ul>	

## 9. Maintenance

 A electrical and mechanical check-up should be done every year.  
Disconnect the pendant system from the mains before any maintenance work to prevent electric shock.

 Check points on maintenance work

- Defects of paint
- Plastic fissures
- Loosened parts.
- Free rotatability / limit stops and deformation of the suspension.
- The connection between LIGHTHEAD and pendant system.
- The faultless function of the LIGHTHEAD.

 In case of failure or damage, please contact your supplier.

## 10. Troubleshooting

### 10.1 General troubleshooting

No.	Problem	Cause	Corrective action
1	If the LED light on the LIGHTHEAD does not turn on.	Power cut	Check if supply mains are operating.
		etc	Turn off the Main Power Switch more than 30 seconds and Turn on the Main Power Switch. please contact your supplier
2	If there is an error in the light pattern formation.	Inappropriate distance	Check if recommended distance(70cm) between the LIGHTHEAD to the chair unit. If the condition does not improve, do not attempt to repair. Please contact your supplier.
3	If the SAFETY COVER of the LIGHTHEAD is polluted.	Pollution	Cleanse it with designated chemicals (Alcohol, Ethanol). If the essential performances of the device (Intensity of Illumination, Color Temperature) are seriously impaired, please contact your supplier.

## 11. Disposal





- For environment and safety of human, wastes must be recycled or separated.
- The materials should be carefully separated.
- The electrical boards should be submitted to an appropriate recycling proceeding
- The cardboard box may be recycled with other paper products.

· Please contact the closest DENTIS branch or your supplier, if you have any questions about recycling of the device.

## 12. Model designation

Head	Mount Type	Camera	Colour	Resin cover	Remote control	Adapter
C300 C400	H=Head C=Chair W=Wall E=Ceiling M=Mobile	0 = None 1 = Camera(x30) 2=Camera(4K)	S=single M=Multi	0 = None 1 = Resin cover	A=None B=Remote control	0 = None 1 = Adapter

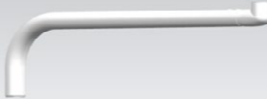
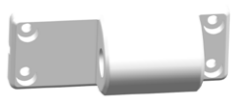
## 13. List of components

FIRST MAIN ARM	SECOND MAIN ARM	WALL BRACKET	CEILING COVER
			
CEILING VERTICAL ARM	ADAPTER	HANDLE	C300 LIGHT HEAD
			
C400 LIGHT HEAD			
			

## 15. Manufacturer and Factory

**Manufacturer, Factory :** DENTIS MEDICAL DIVISION  
6, Yuram-ro, Dong-gu, Daegu, Republic of Korea

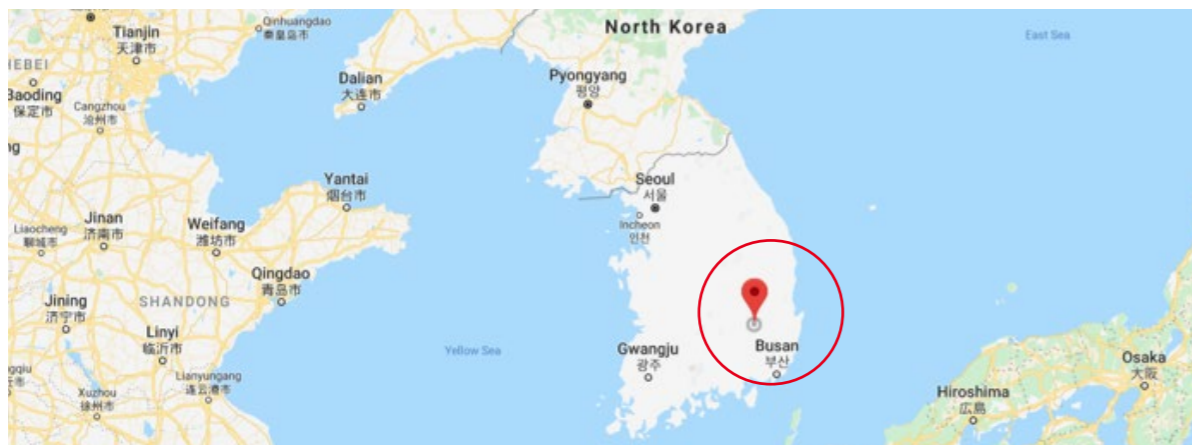

## 16. Europe Representative

**Location of KTR Europe GmbH.** Mergenthalerallee 77, 65760 Eschborn, Germany

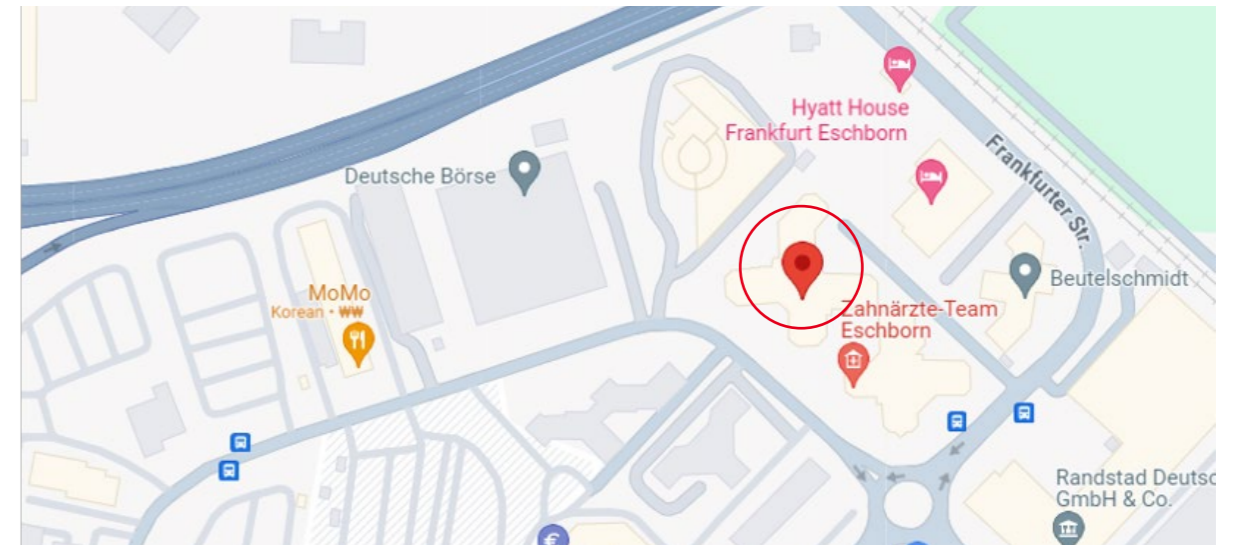





## DENTIS

---

**DENTIS Co., Ltd. (HEADQUARTERS)** 87, Yuram-ro Dong-gu, Daegu, Republic of KOREA Tel +82-53-583-2804 Fax +82-53-583-2806  
**DENTIS MEDICAL DIVISION(FACTORY)** 6, Yuram-ro, Dong-gu, Daegu, Korea Tel. +82-70-7730-4146 Email. luvis@luvis.co.kr

EL109P-PM150